

# B-PRIMIS ET-PRO series



Copyright © Berghof Automation GmbH

Reproduction and duplication of this document and utilisation and communication of its content are prohibited without our express permission. All rights reserved.

Infringements will result in compensation for damages.

### **Disclaimer**

The content of this document has been checked for conformity with the hardware and software described. It is, however, impossible to rule out all discrepancies. As a result, we cannot be held responsible if the content is not fully compliant. The information in this document is checked regularly and any necessary corrections are included in subsequent editions. Suggestions for improvement are always welcome. Subject to technical modifications.

### **Trademarks**

- CANtrol® and CANtrol®-dialog are registered trademarks of Berghof Automation GmbH.
- Microsoft®, Windows® and the Windows® logo are registered trademarks of Microsoft Corp. in the USA and other countries.
- EtherCAT® is a registered trademark and a patented technology, licensed by Beckhoff Automation GmbH, Germany.
- CiA® and CANopen® are registered community trademarks of CAN in Automation e. V.
- ARM® and Cortex® are registered trademarks of ARM Limited.
- PROFINET® is a registered trademark of PROFIBUS Nutzerorganisation e.V.
- Modbus® is a registered trademark of the Modbus-IDA organisation.
- i.MX6 is a registered trademark of Freescale.

The rights of all companies and company names mentioned in this document as well as products and product names belong to the respective companies.

### **Notes about this handbook**

This equipment handbook contains information which is specific to the product and valid at the time of printing.

This equipment handbook is only complete in conjunction with the product-related hardware and software manuals required for the specific application.

You can contact us at:

Berghof Automation GmbH

Arbachtalstrasse 26

72800 Eningen

Germany

T +49.7121.894-0

F +49.7121.894-100

Email: [controls@berghof.com](mailto:controls@berghof.com)

[www.berghof-automation.com](http://www.berghof-automation.com)

Berghof Automation GmbH is certified to DIN EN ISO 9001 in the respective current version.

## Revision log

Version	Date	Description
0.1	26/09/2019	Initial version
0.9	24/04/2020	Catalogue numbers
1.0	18/06/2020	Formatting revised in the document
1.1	01/06/2021	small corrections
1.2	17/11/2023	Adaption cyber security

## Table of contents

<b>1.</b>	<b>GENERAL INFORMATION</b>	<b>7</b>
1.1.	Notes about this handbook	7
1.2.	Symbols and visual depictions	7
1.3.	Hazard categories and indications	8
1.4.	Qualified personnel	9
1.5.	Duty of care	9
	General	9
1.6.	Intended use	10
1.7.	Transport and storage	11
	Transport and storage	11
	Devices with (rechargeable) batteries	11
	Operation	11
1.8.	Unpacking	11
<b>2.</b>	<b>SAFETY</b>	<b>12</b>
2.1.	Safety-related systems	12
2.2.	Safety instructions	12
	Working on the device	12
2.3.	Cybersecurity	13
<b>3.</b>	<b>PRODUCT DESCRIPTION</b>	<b>14</b>
3.1.	Overview	15
3.1.1.	B-Primis ET-Pro 4	15
3.1.2.	B-Primis ET-Pro 7	16
3.1.3.	B-Primis ET-Pro 10/15	17
3.2.	Scope of delivery and accessories	17
	Scope of delivery	17
	Accessories	17
3.3.	Product features	18
	Assembly	18
	Processor	18
	Ethernet	18
	USB	18
	Additional interfaces	18
	microSD card	18
	Summary of features	18
<b>4.</b>	<b>ASSEMBLY</b>	<b>19</b>
4.1.	Preparation for installation	19
4.1.1.	ET-Pro 4 dimensions	19
4.1.2.	ET-Pro 4 installation cut-out	20
4.1.3.	ET-Pro 7 dimensions	21
4.1.4.	ET-Pro 7 installation cut-out	22

4.1.5.	ET-Pro 10 dimensions .....	23
4.1.6.	ET-Pro 10 installation cut-out .....	24
4.1.7.	ET-Pro 15 dimensions .....	25
4.1.8.	ET-Pro 15 installation cut-out .....	26
<b>4.2.</b>	<b>Installation .....</b>	<b>27</b>
4.2.1.	ET-Pro 4/7 installation .....	27
4.2.2.	ET-Pro 10 installation .....	29
4.2.3.	ET-Pro 15 installation .....	31
<b>5.</b>	<b>CONNECTION .....</b>	<b>33</b>
<b>5.1.</b>	<b>Power supply .....</b>	<b>33</b>
5.1.2.	Connecting the power supply .....	34
5.1.3.	ET-Pro 4/7 power supply .....	34
5.1.4.	ET-Pro 10/15 power supply .....	35
<b>5.2.</b>	<b>Data connections .....</b>	<b>36</b>
5.2.1.	Block diagram.....	36
5.2.2.	Ethernet.....	37
5.2.3.	USB.....	38
<b>6.</b>	<b>OPERATION .....</b>	<b>39</b>
<b>6.1.</b>	<b>Switching on and off .....</b>	<b>39</b>
<b>6.2.</b>	<b>Initial start-up of the network .....</b>	<b>40</b>
6.2.1.	VNC client configuration .....	40
6.2.2.	Web terminal configuration .....	42
<b>6.3.</b>	<b>Operation .....</b>	<b>44</b>
6.3.1.	Status indicators.....	44
6.3.2.	microSD card.....	45
<b>6.4.</b>	<b>Troubleshooting .....</b>	<b>46</b>
6.4.1.	No network connection .....	46
<b>7.</b>	<b>SERVICING / MAINTENANCE .....</b>	<b>46</b>
<b>7.1.</b>	<b>Maintenance.....</b>	<b>46</b>
<b>7.2.</b>	<b>Cleaning .....</b>	<b>47</b>
<b>7.3.</b>	<b>Chemical resistance.....</b>	<b>47</b>
7.3.1.	Resistance of the touch screen .....	47
7.3.2.	Resistance of the front membrane display .....	48
<b>8.</b>	<b>DISASSEMBLY .....</b>	<b>49</b>
<b>8.1.</b>	<b>ET-Pro 4/7 disassembly .....</b>	<b>49</b>
<b>8.2.</b>	<b>ET-Pro 10/15 disassembly .....</b>	<b>50</b>
<b>8.3.</b>	<b>Disposal .....</b>	<b>52</b>
<b>9.</b>	<b>INFORMATION AND OPTIONS .....</b>	<b>53</b>
<b>9.1.</b>	<b>Type plate.....</b>	<b>56</b>
<b>9.2.</b>	<b>Device variants and identification .....</b>	<b>57</b>
<b>9.3.</b>	<b>Options and extensions.....</b>	<b>57</b>

<b>10.</b>	<b>STANDARDS AND CERTIFICATES .....</b>	<b>58</b>
<b>10.1.</b>	<b>Standards.....</b>	<b>58</b>
<b>10.2.</b>	<b>Declaration of conformity/Technical data .....</b>	<b>59</b>
<b>11.</b>	<b>CUSTOMER SERVICES / ADDRESSES .....</b>	<b>60</b>
<b>11.1.</b>	<b>Customer services .....</b>	<b>60</b>
<b>11.2.</b>	<b>Repair service.....</b>	<b>60</b>
<b>11.3.</b>	<b>Addresses.....</b>	<b>61</b>
<b>12.</b>	<b>APPENDIX.....</b>	<b>62</b>
<b>12.1.</b>	<b>Notes on copyright and the software licence .....</b>	<b>62</b>
<b>12.2.</b>	<b>List of figures.....</b>	<b>62</b>

# 1. General information

This user handbook is intended for use by qualified personnel and contains information on the assembly, installation, start-up and maintenance of the device.

## 1.1. Notes about this handbook

This user handbook is a component of the product and applies to the following devices:

- B-Primis ET-Pro 4
- B-Primis ET-Pro 7
- B-Primis ET-Pro 10
- B-Primis ET-Pro 15

It contains information on the following topics:

- Areas of application
- Safety
- Mechanical design
- Electrical design
- Connections
- Start-up
- Servicing and maintenance
- Decommissioning
- Disposal

- ▶ Keep this user handbook available alongside the product at all times.

## 1.2. Symbols and visual depictions

The following symbols and visual depictions are used in this user handbook:

Symbol	Meaning
→ ...	List entry
▶ ...	Individual instruction or list of instructions which can be carried out in any order.
1. ... 2. ...	List of instructions which must be carried out in the order given.
	Additional product information

**Structure of the warnings:**

**⚠ WARNING**

<b>Optional:</b>	<b>Type and source of the danger</b>
More symbols	Brief description and consequences ▶ Preventive measures

---

### 1.3. Hazard categories and indications

The following indications are used for warning messages that must be observed to ensure your personal safety and avoid any damage to property.

The indications have the following meanings:

**⚠ DANGER**

**Serious injury or death**

Failure to observe the safety measures will result in death or serious injury.

- ▶ Take preventive measures.
- 

**⚠ WARNING**

**Possible serious injury or death**

Failure to observe the safety measures may result in death or serious injury.

- ▶ Take preventive measures.
- 

**⚠ CAUTION**

**Possible minor injuries**

Failure to observe the safety measures may result in minor injuries.

- ▶ Take preventive measures.
- 

**NOTICE**

**Possible damage to property**

Failure to observe the safety measures may result in damage to property.

- ▶ Take preventive measures.
-



## 1.4. Qualified personnel

The installation, start-up and maintenance of the machine must be carried out by qualified personnel. For the purposes of this documentation and the safety instructions contained therein, “qualified personnel” means trained staff with the authorisation to assemble, install, start up, earth and identify devices, systems and electrical circuits in accordance with the standards set in safety engineering and who are familiar with safety concepts in automation engineering.

## 1.5. Duty of care

### General

The user or processor (OEM) must ensure the following:

- The device must only be used for its intended purpose.
- The device must only be used in a perfect, fully functional condition.
- The user handbook must always be kept legible and fully available.
- Only sufficiently qualified and authorised personnel carry out assembly, installation, start-up and maintenance of the device.
- This authorised personnel must receive regular training in all relevant questions of occupational health and safety and environmental protection and must be familiar with the contents of this user handbook, particularly the sections containing safety instructions.
- Any markings or identification labels and safety and warning signs on the device must not be removed and must be kept legible at all times.
- The national and international regulations regarding the operation of machinery and installations where the device is being used must be observed.
- The user must always be kept abreast of any current relevant information regarding the device and its use or operation.
- The user is responsible for coordinating the use of the safety-related control components with the responsible authority and for adhering to its specifications.

## 1.6. Intended use

The device is a component of a modular automation system for industrial control applications in the medium to high performance range.

The automation system is designed for use in overvoltage category I (IEC 364-4-443) for the control and regulation of machinery and industrial processes in low-voltage installations in accordance with the following basic conditions:

- Maximum rated supply voltage of 1,000 V AC (50/60 Hz) or 1,500 V DC
- For use in an environment with max. category 2 level of pollution (EN 61010-1).
- For use in a maximum altitude of 2,000 m a.s.l.
- For indoor use in areas not exposed to direct UV radiation
- Max. ambient temperature inside and outside the control cabinet according to the technical specifications (see "Information and options").

Correct and safe operation of the automation system requires qualified project planning, proper transport, storage, installation and use as well as careful maintenance.

The automation system may only be used within the scope of the information and applications specified in this documentation and associated user handbooks.

The automation system must only be used as follows:

- As intended
  - In technically perfect condition
  - Without unauthorised modifications
  - By qualified users only
- 
- ▶ Observe the rules of the employers' liability insurance association, the German Technical Inspection Association (TÜV), the Association of German Electrical Engineers (VDE) or relevant national regulations.

The device is intended for installation in a suitable installation cut-out in industrial machines and systems in indoor areas.

- ▶ During installation, make sure that the existing seal profiles are undamaged.
- ▶ For operation, refer to the applicable ambient conditions (see "Information and options").

## 1.7. Transport and storage

The device is susceptible to impacts, heavy vibrations, moisture and extreme temperatures.

### Transport and storage

- ▶ Protect the device from heavy mechanical stresses during transport.
- ▶ Always transport the device in its original packaging.
- ▶ For storage, refer to the applicable ambient conditions (see “Information and options”).
- ▶ Protect the device from condensation and moisture.

### Devices with (rechargeable) batteries

Lithium metal batteries are a hazardous material. According to the manufacturers, they fall under UN 3091 (contained in the device).

Special provision 188 of the ADR can be applied for transport.

### Operation

- ▶ If the device has been stored or transported in cold weather or under conditions of large fluctuations in temperature, do not start to operate it until it has acclimatised to room temperature for the place in which it is used.
- ▶ Wait at least 12 hours after it has reached room temperature before operating the device.

## 1.8. Unpacking

Upon receipt of the device, make sure that it is undamaged and complete.

- ▶ Check the packaging for external damage.
- ▶ If the packaging is seriously damaged or if damage to the contents is evident: do not proceed further with opening the packaging; instead immediately inform the transport company and your supplier.
- ▶ Remove the packaging and keep it safe for subsequent transport.
- ▶ Check the contents for evidence of damage in transport.
- ▶ Check the contents for completeness against the order documentation and keep all delivery documentation for future reference. The delivery documentation contains important information about the device and is part of the product.
- ▶ If you notice any damage in transport or the contents do not match the order: inform the suppliers immediately.

## 2. Safety

### 2.1. Safety-related systems

The use of PLC controls in safety-related systems requires specific measures. If a PLC controller is to be used in a safety-related system, the user must be given comprehensive advice by the PLC manufacturer in addition to any available standards or guidelines regarding safety installations.

- ▶ Before starting work on the devices, switch off all power supplies, including those of connected peripherals.
- ▶ Keep all ventilation openings unobstructed.

The failure of certain components in an electronic control system may result in uncontrolled and/or unpredictable operational behaviour.

- ▶ All types of failure must be considered at the system level and the associated preventative measures identified.
- ▶ If necessary, request information from your automation system provider.

### 2.2. Safety instructions

#### CAUTION

##### **Possible minor injuries and/or burning of the surface of the skin**

Non-compliance with the safety features may result in minor injuries / burning of the surface of the skin

The device may only be operated only when it is in good working order. Exposed sharp edges or broken glass pose an injury risk.

- ▶ If you detect damage to the front glass of the device, stop operating the device and immediately disconnect it from the power supply.

The device may heat up during operation, especially in hot environments, because of the passive cooling mechanism of the electronics inside. The surface temperature may be high enough to cause burning if there is prolonged contact with the human skin.

- ▶ If possible, avoid touching the rear panel of the device during operation.
- ▶ If you plan to work on e.g. the installation or cabling of the device, first shut it down by disconnecting the power supply and let it cool down for a while.
- ▶ It is recommended to wear personal protective equipment, e.g. protective gloves when handling the warmed up device.

##### **Working on the device**

Do not start work on the device until all necessary safety precautions have been taken. Take precautions to avoid unforeseeable functional events and movements of the system.

- ▶ Bring the system into a safe state.
- ▶ Switch the system and the device off.
- ▶ Secure the system against being switched on again.
- ▶ Disconnect the device from the system.

Do not open the device housing.

- ▶ If it is necessary to work on internal parts of the device, contact the manufacturer (see “Addresses”).

## 2.3. Cybersecurity

- ▶ Never place the control unit on the Internet without additional protection mechanisms, this product is not designed for this purpose
- ▶ Change the default passwords specified on delivery
- ▶ Always use an upstream external firewall to prevent access from the outside to the inside.
- ▶ Use the security mechanisms of VPN server portals (e.g. IXON) to which the controller can actively connect via VPN or comparable mechanisms
- ▶ Always use https instead of http
- ▶ Deactivate unnecessary services such as (FTP/SSH/Webserver)

Contact person for cybersecurity of Berghof products:

**Berghof Automation Product Security Incident Response Team**

[psirt.automation@berghof.com](mailto:psirt.automation@berghof.com)

### **3. Product description**

The operating panels of the B-Primis ET-Pro series are first-class display and input devices with high-quality frames in analogue-resistive technology, which are connected to a control system for machines or plants via Ethernet interfaces. The terminal shows CODESYS Web visualisation or CODESYS Target visualisation, irrespective of whether the visualisation originates from a Berghof PLC control unit or another compatible CODESYS control unit.

The device's connection area for all external connections is located at the rear. These devices are intended for installation on a flat surface in a pre-prepared installation cut-out.

All the connections are of the plug-in type.

### 3.1. Overview

#### 3.1.1. B-Primis ET-Pro 4

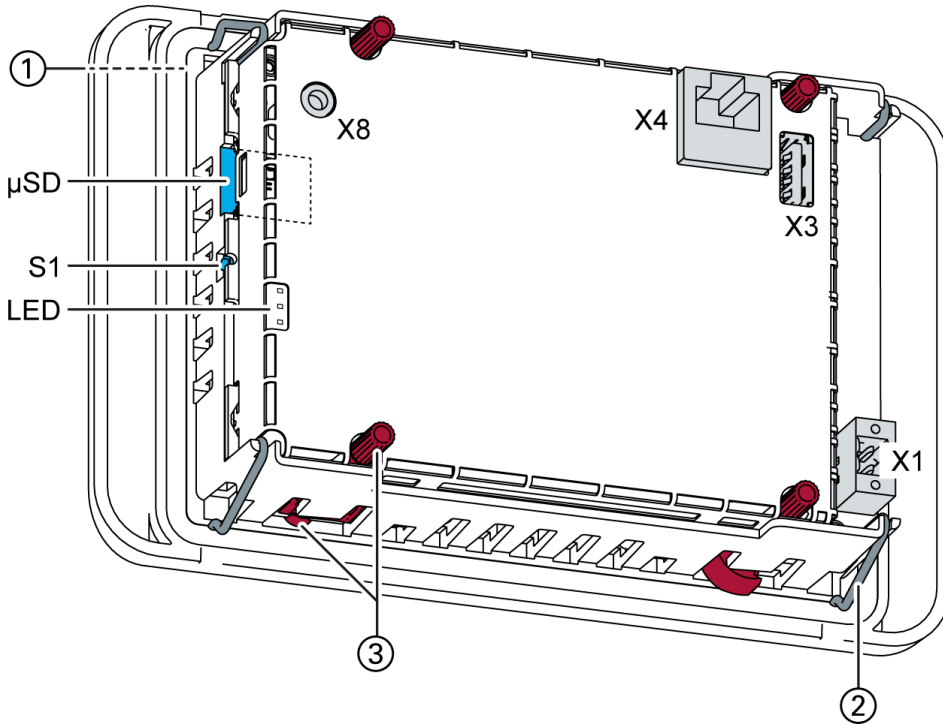

Fig. 1: Overview of ET-Pro 4 (rear)

No.	Designation	No.	Designation
1	Display 4.3 inch	X1	Power supply
2	Fastening clip (4 pcs)	X3	USB 2.0
3	Twist-lock catch (4 pcs) <sup>1</sup>	X4	Ethernet (ETH0)
S1	No function	X8	Debug interface
LED	LEDs: PWR, Run/Stop, Error	μSD	microSD card connection (for future applications)

<sup>1</sup> Only required for protection rating IP65

### 3.1.2. B-Primis ET-Pro 7

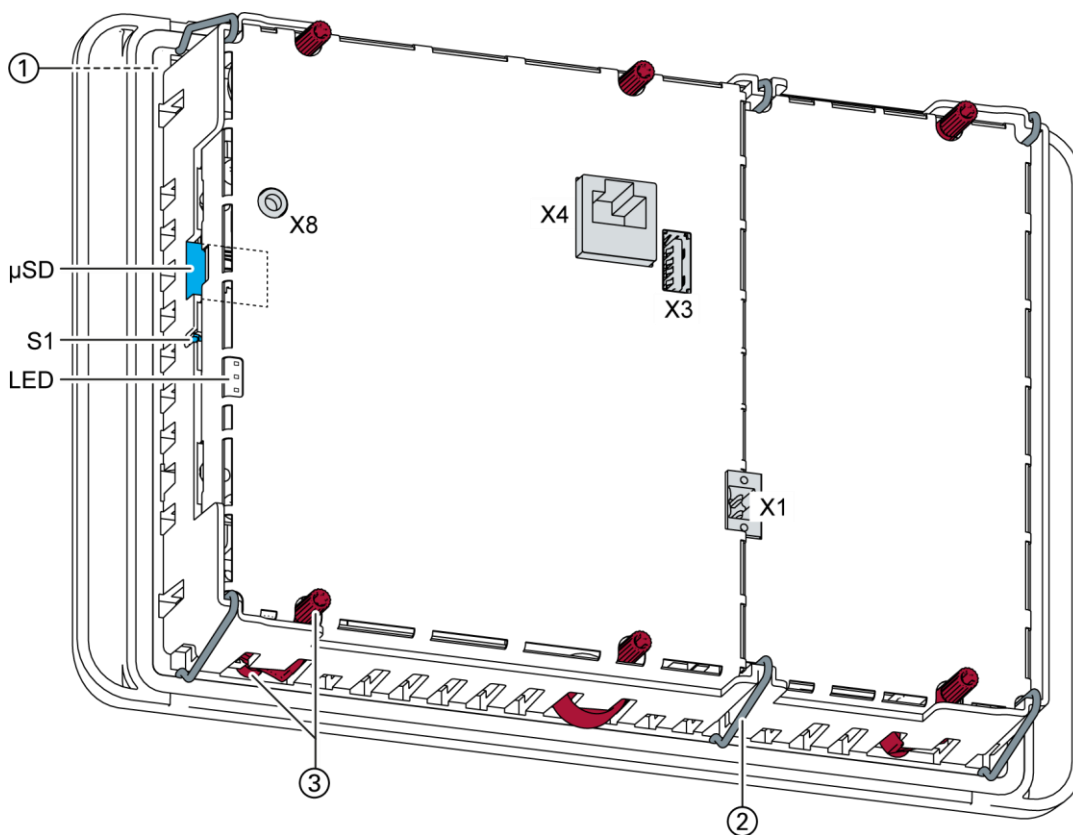

Fig. 2: ET-Pro 7 (at the rear)

No.	Designation	No.	Designation
1	7-inch display	X1	Power supply
2	Fastening clip (6 pcs)	X3	USB 2.0
3	Twist-lock catch (6 pcs) <sup>1</sup>	X4	Ethernet (ETH0)
S1	No function	X8	Debug interface
LED	LEDs: PWR, Run/Stop, Error	μSD	microSD card connection (for future applications)

<sup>1</sup> Only required for protection rating IP65



### 3.1.3. B-Primis ET-Pro 10/15

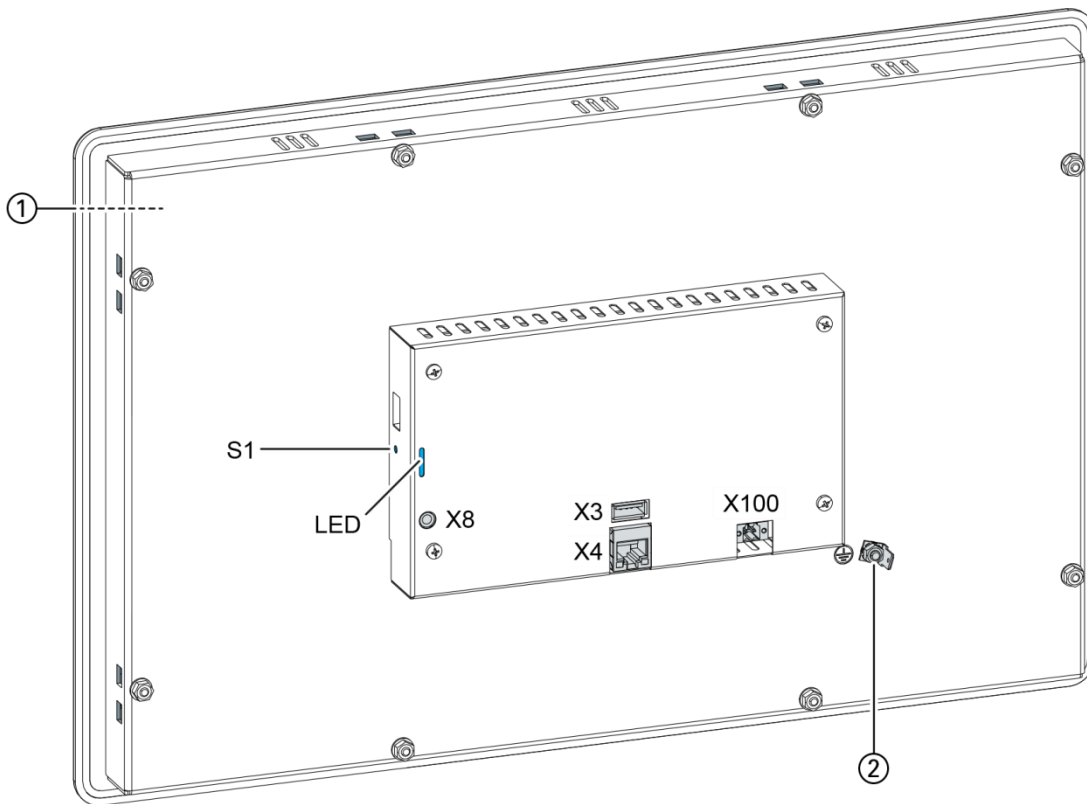

Fig. 3: ET-Pro 10/15 (rear)

No.	Designation	No.	Designation
1	10.1/15.6-inch display	X8	Debug interface (do not use – for Berghof service staff only)
2	Earth connection	X10	Power supply
		0	
X3	USB 2.0	S1	Function key (do not use – for Berghof service staff only)
X4	Ethernet (ETH0)	LED	LEDs: PWR, Run/Stop, Error

## 3.2. Scope of delivery and accessories

### Scope of delivery

→ B-Primis ET-Pro device

### Accessories

The following accessories are available as options H001 or separately via the order number.

Order number	Valid for	Remarks
S-02020201-0100	ET-Pro 4	Connector: 2-pin plug-in connector for the power supply Weidmüller BLZF 3.50/02/180
	ET-Pro 7	
	ET-Pro 10	
	ET-Pro 15	

### 3.3. Product features

#### Assembly

The device is designed for installation in a front panel or in a control cabinet in a rough industrial environment.

#### Processor

In its basic configuration, the device is equipped with an 800 MHz ARM® CPU with a Cortex™ A9 core. Customer-specific variants are available, which instead of a single core processor are equipped with a dual core or quad core processor.

#### Ethernet

The device has an Ethernet interface with 10/100 Mbit/s. This is used for standard Ethernet connections. The TCP/IP and UDP protocols permit flexible connections to visualisation software, upstream control units and to the IT infrastructure.

#### USB

The USB host interface allows a wide range of peripherals to be connected to the device. This allows a USB thumb drive to be used for updating the application or for downloading data directly.



USB thumb drives with FAT/FAT32 formatting are supported.

If you require support for other USB formats, please contact our Technical Support team.

#### Additional interfaces

There is also a debugging interface located on the device which is accessible via a 3.5-mm jack plug with a special cable (contact Customer Services if necessary).

#### microSD card

The microSD card interface is designed for future applications.

#### Summary of features

- ARM® CPU with Cortex™-A9 single core (800 MHz; optional dual core or quad core)
- User program and data memory (RAM): 512 MB onboard
- User program memory (flash) 512 MB onboard
- 1 USB host interface (USB 2.0)
- 1 Ethernet 10/100 Base T interface

## 4. Assembly

### 4.1. Preparation for installation

The devices are intended for installation in a rectangular cut-out on a front panel. The support material must be rigid.

Prerequisites:

- The device must have a clear space of at least 20 mm all round at the rear, to allow sufficient air circulation.
- The max. surrounding air temperature in the control cabinet must not exceed 55°C during operation.
- The support material for the installation cut-out must be of the specified thickness (see installation cut-out) and must be flat and sufficiently stable.

#### NOTICE

##### Damage to the device!

Installation on uneven support material can lead to mechanical stresses and cracks in the front face or to malfunctioning of the touch screen.

- ▶ Make sure that the mounting points of the device are all in a common plane, with no more than maximum  $\pm 0.5$  mm variation.

#### 4.1.1. ET-Pro 4 dimensions

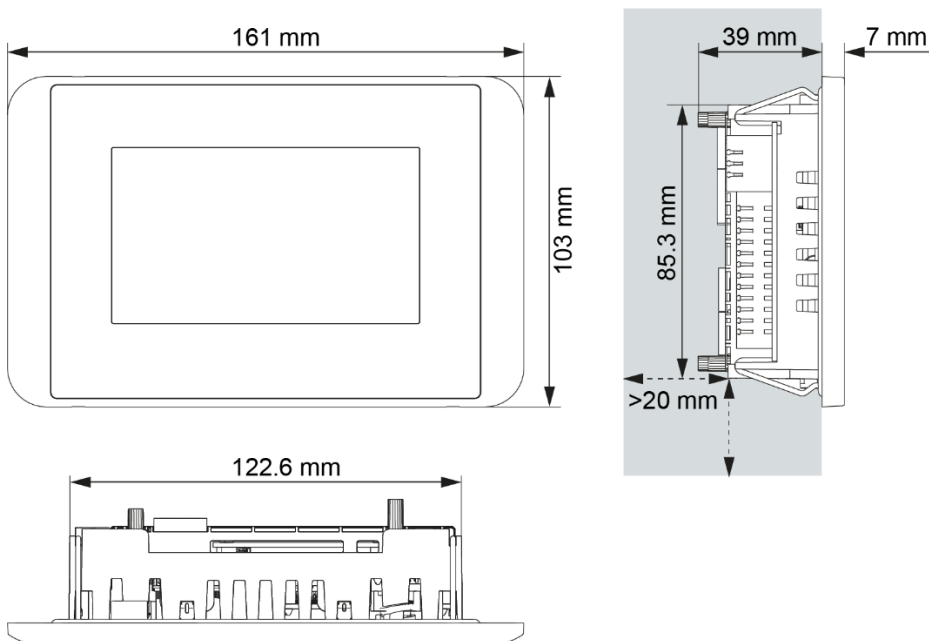

Fig. 4: ET-Pro 4 dimensions

#### 4.1.2. ET-Pro 4 installation cut-out

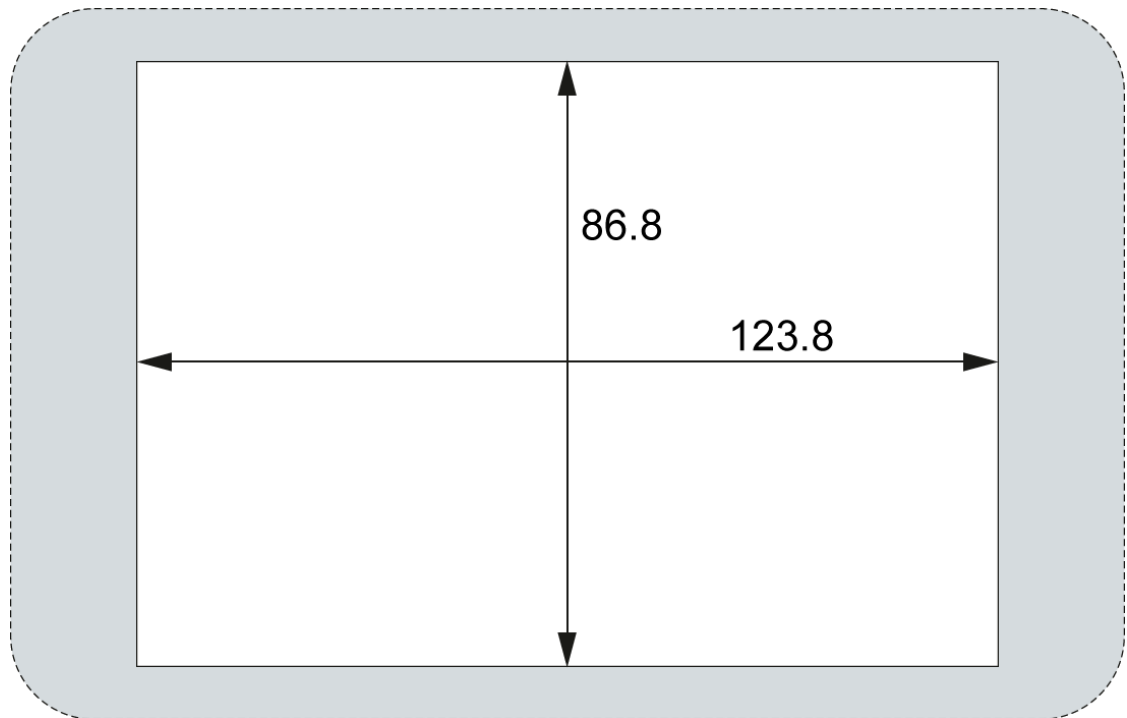

Fig. 5: ET-Pro 4 installation cut-out

- ▶ Cut a rectangular installation cut-out in the support material:  
 Height: 86.8 mm  
 Width: 123.8 mm  
 Max. corner radius: 3.0 mm
  
- i** Optimum thickness of support material:  
 Protection rating IP65 with twist-lock catches: only at 1.5–3.0 mm  
 Optimum: 1.5–2.0 mm  
 Max. 3.0 mm

### 4.1.3. ET-Pro 7 dimensions

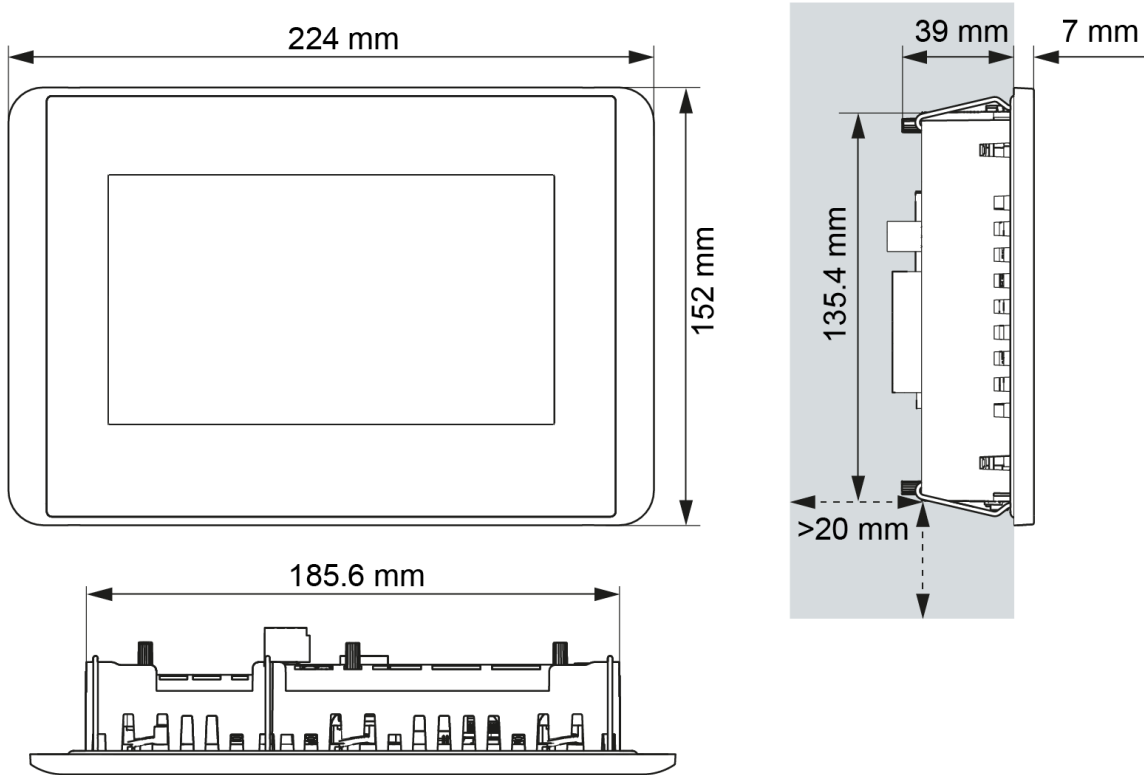

Fig. 6: ET-Pro 7 dimensions

#### 4.1.4. ET-Pro 7 installation cut-out

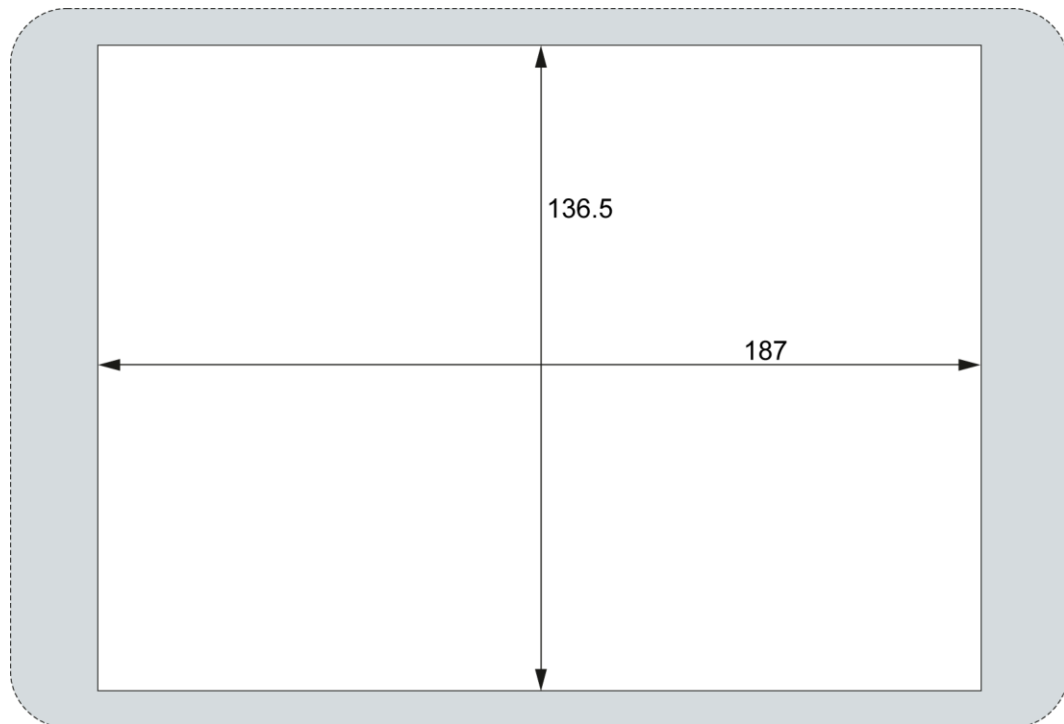

Fig. 7: ET-Pro 7 installation cut-out

- ▶ Cut a rectangular installation cut-out in the support material:  
Height: 136.5 mm  
Width: 187.0 mm  
Max. corner radius: 3.0 mm
  
- i** Optimum thickness of support material:  
Protection rating IP65 with twist-lock catches: only at 1.5–3.0 mm  
Optimum: 1.5–2.0 mm  
Max. 3.0 mm

### 4.1.5. ET-Pro 10 dimensions

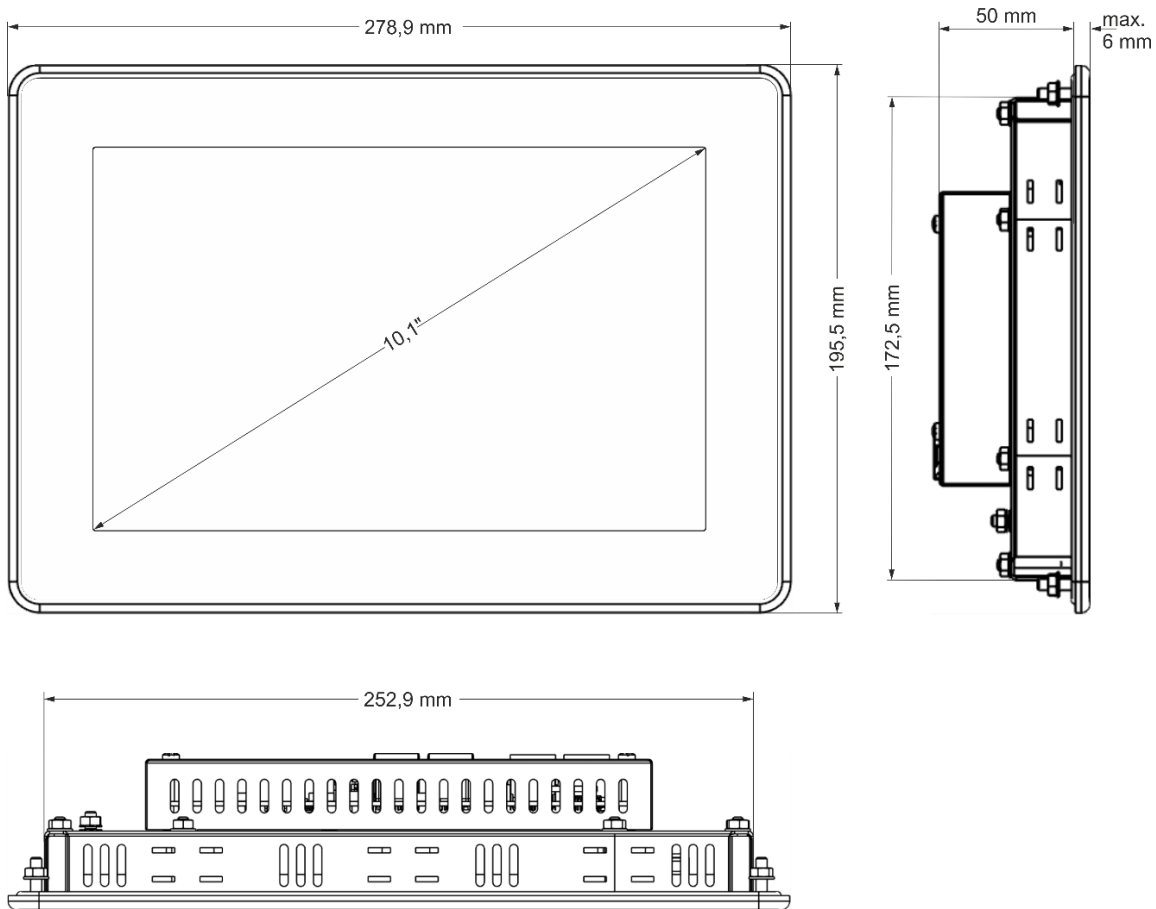

Fig. 8: ET-Pro 10 dimensions

#### 4.1.6. ET-Pro 10 installation cut-out

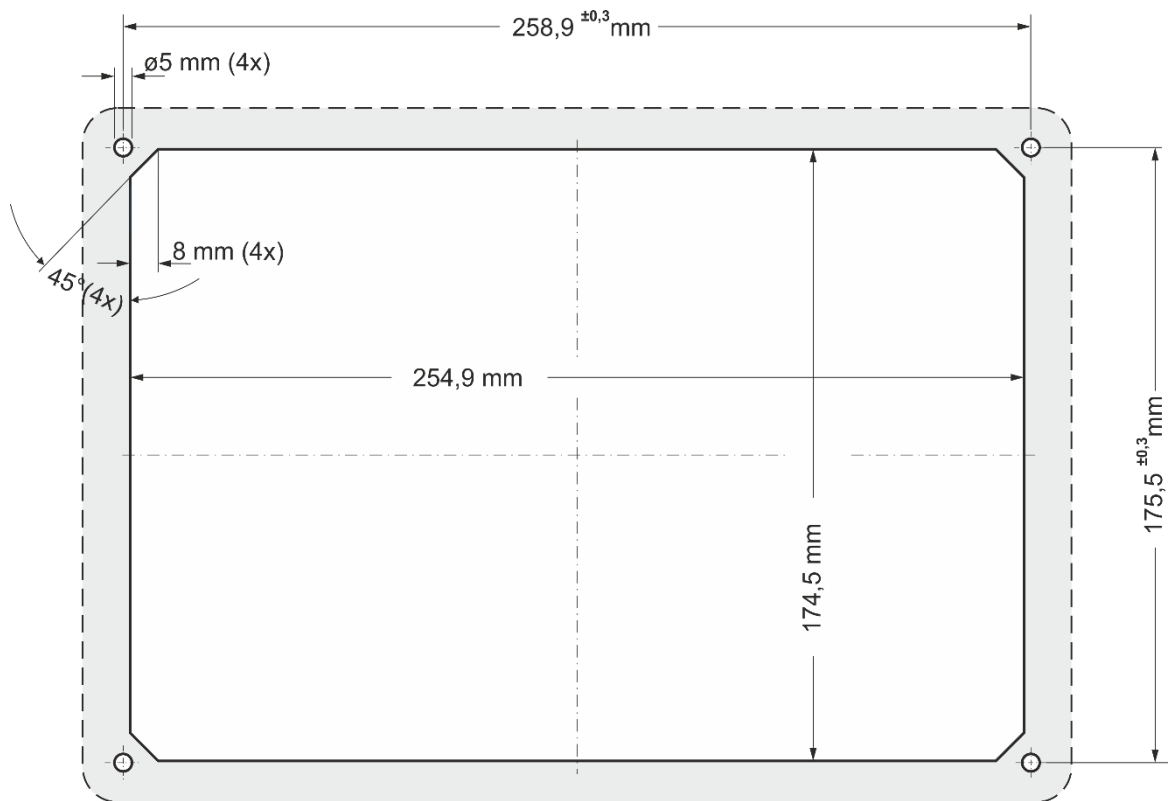

Fig. 9: ET-Pro 10 installation cut-out

- ▶ Cut a rectangular installation cut-out in the support material:  
 Height: 174.5 mm  
 Width: 254.9 mm  
 Max. corner radius: 3.0 mm



Optimum thickness of support material:  
 Protection rating IP65 with additional tensioning clamps: only at 1.5–3.0 mm  
 Optimum: 1.5–3.0 mm  
 Max. 4.0 mm



### 4.1.7. ET-Pro 15 dimensions

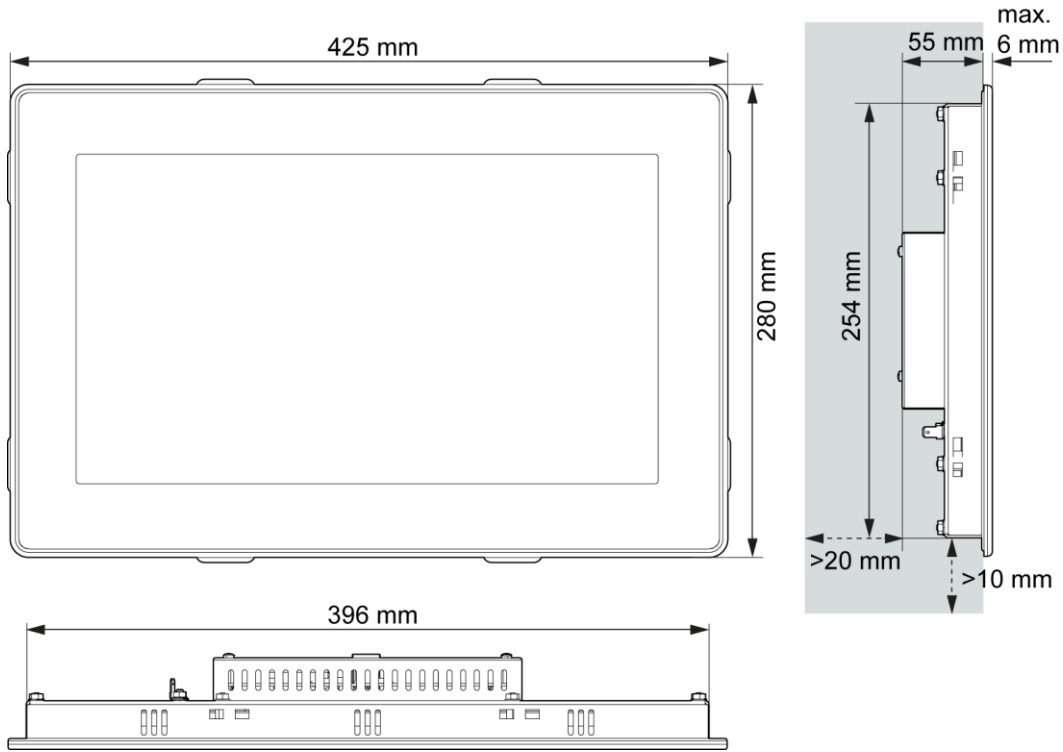

Fig. 10: ET-Pro 15 dimensions

#### 4.1.8. ET-Pro 15 installation cut-out

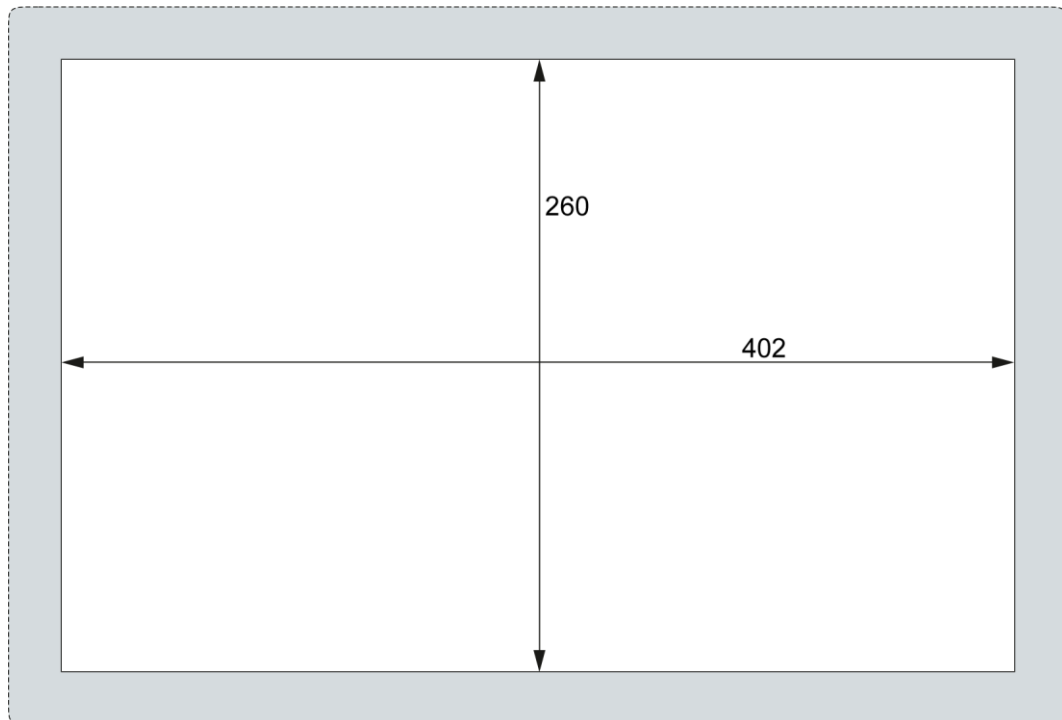



Fig. 11: ET-Pro 15 installation cut-out

- ▶ Cut a rectangular installation cut-out in the support material:
  - Height: 260 mm
  - Width: 402 mm
  - Max. corner radius: 3.0 mm
  
-  Optimum thickness of support material:
  - Optimum: 2.0–3.0 mm
  - Max. 4.0 mm

## 4.2. Installation

### 4.2.1. ET-Pro 4/7 installation

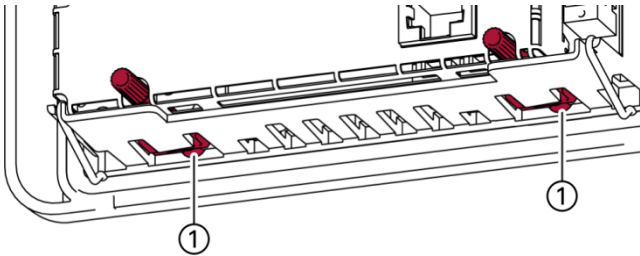

Fig. 12: Opening the twist-lock catches

- 1st Device with twist-lock catches: make sure that the twist-lock catches are turned anti-clockwise to the limit and are fully open (1).

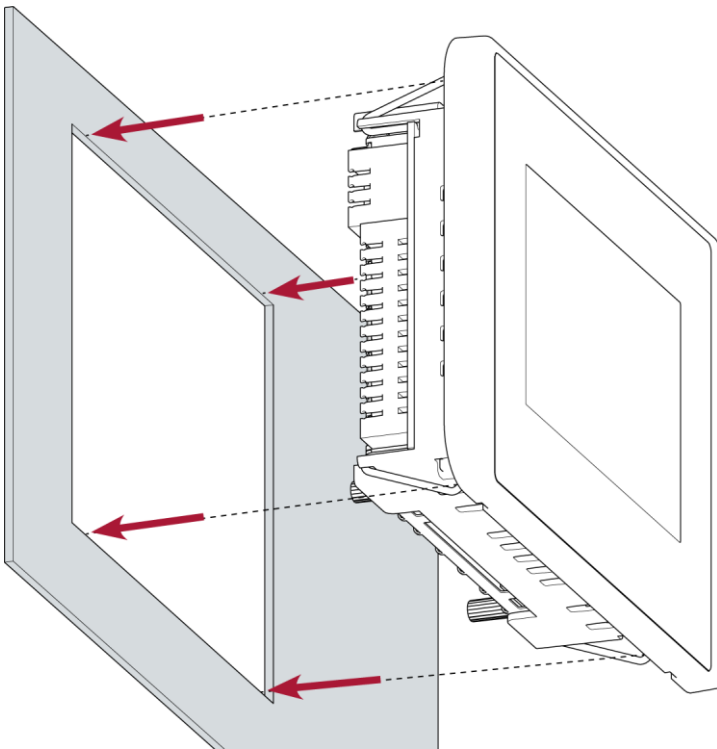

Fig. 13: Installation in an installation cut-out, example with 4 fastening clips

- 2nd Making sure the alignment is correct, push the device evenly into the installation cut-out until the 2 or 3 fastening clips snap into place.

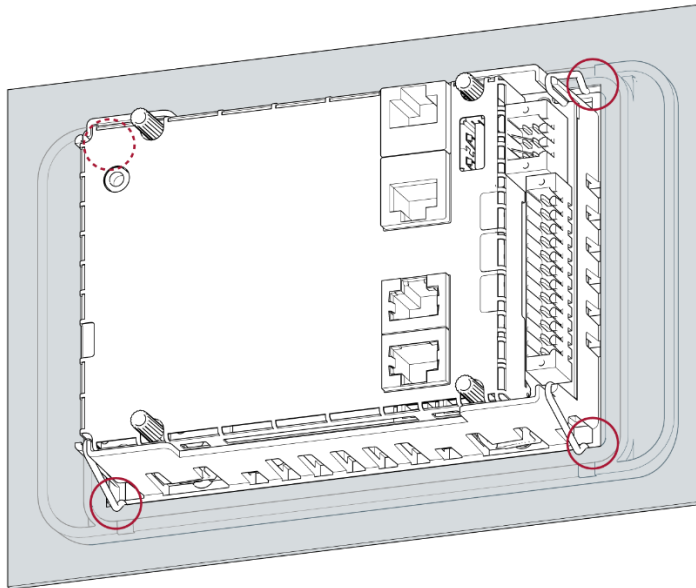



Fig. 14: Device clipped into place in the installation cut-out, example with 4 fastening clips

3rd Make sure that the device is lying flush all round.

4th Device with twist-lock catches: Use a T9x50 screwdriver to tighten the twist-lock catches to a maximum of 0.4 Nm.

	The protection rating IP65 on the front face is only achieved when the twist-lock catches are used correctly.
---	---

## 4.2.2. ET-Pro 10 installation

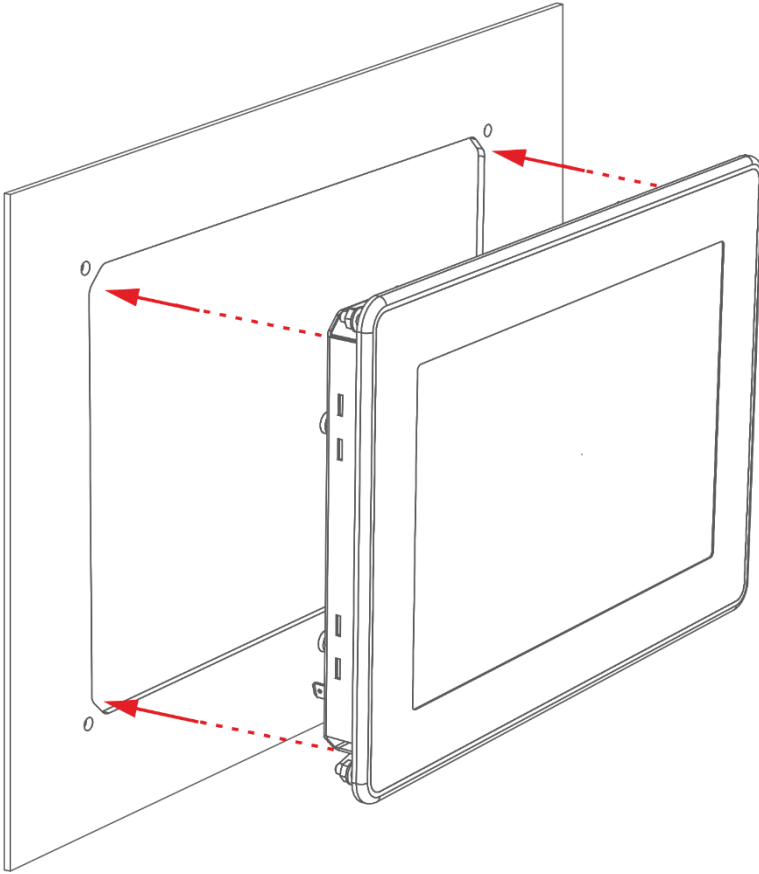

Fig. 15: Installing in the installation cut-out

### Prerequisites:

→ The tensioning clamps are not attached to the device.

- 1st Making sure the alignment is correct, push the device evenly into the installation cut-out.
- 2nd Make sure that the device is lying flush all round.

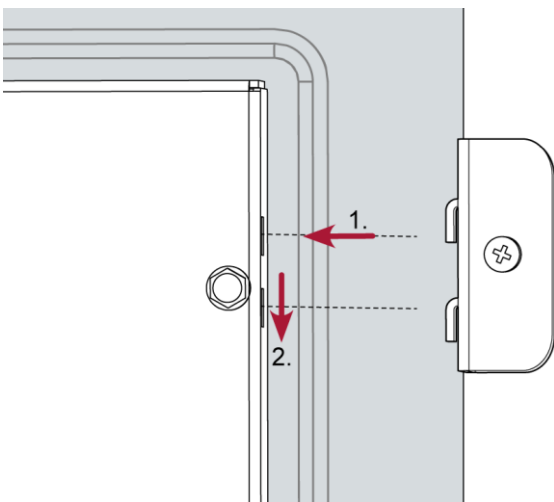

Fig. 16: Hooking in the tensioning clamps (at the rear)

3rd Attach the device with 2 tensioning clamps: Hook in the tensioning clamps diagonally opposite each other on the cover and tighten the screws slightly.

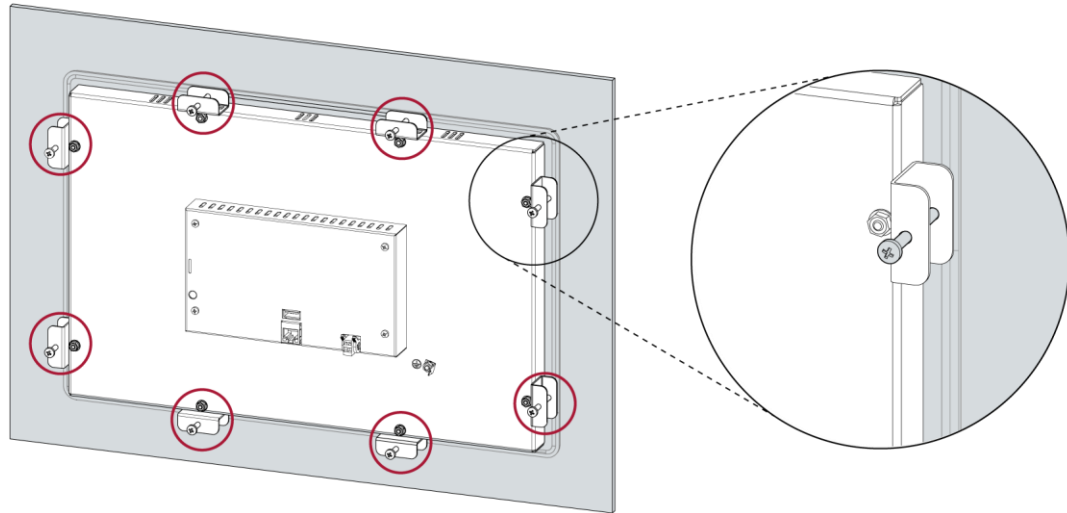

Fig. 17: Tightening the tensioning clamps

4th Hook in the remaining 6 tensioning clamps in the cover and tighten all 8 screws evenly.

## NOTICE

### Damage to the device!

If the device is mounted carelessly, it may fall out of the installation cut-out or get damaged.

- ▶ Do not tilt the device.
- ▶ Secure the device against falling down until the tensioning clamps are attached.

### 4.2.3. ET-Pro 15 installation

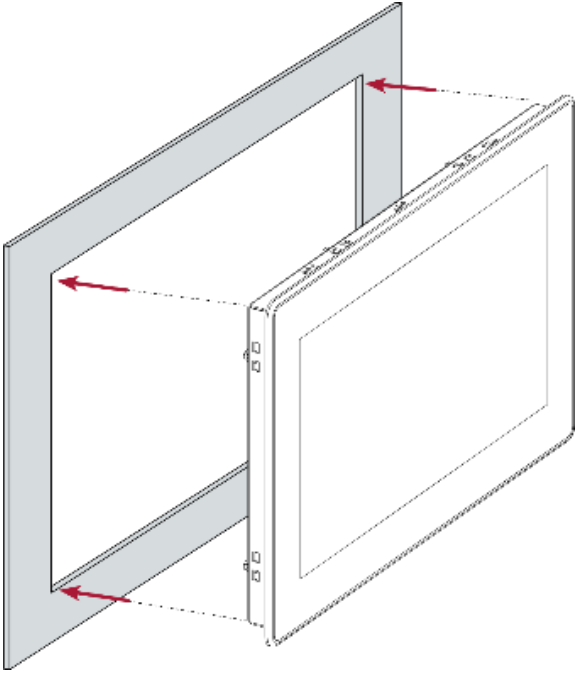

Fig. 18: Installing in the installation cut-out

#### Prerequisites:

→ The tensioning clamps are not attached to the device.

5th Making sure the alignment is correct, push the device evenly into the installation cut-out.

6th Make sure that the device is lying flush all round.

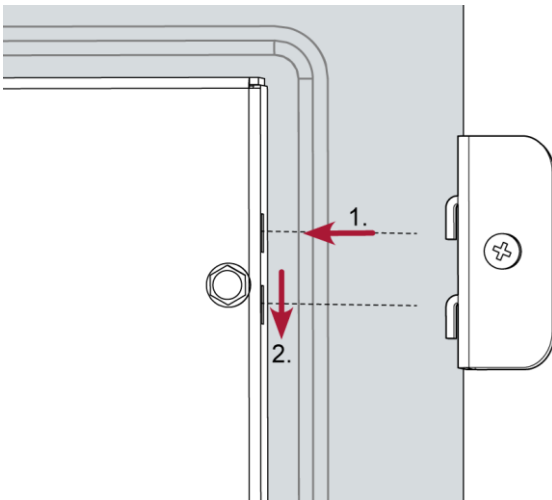

Fig. 19: Hooking in the tensioning clamps (at the rear)

7th Attach the device with 2 tensioning clamps: Hook in the tensioning clamps diagonally opposite each other on the cover and tighten the screws slightly.

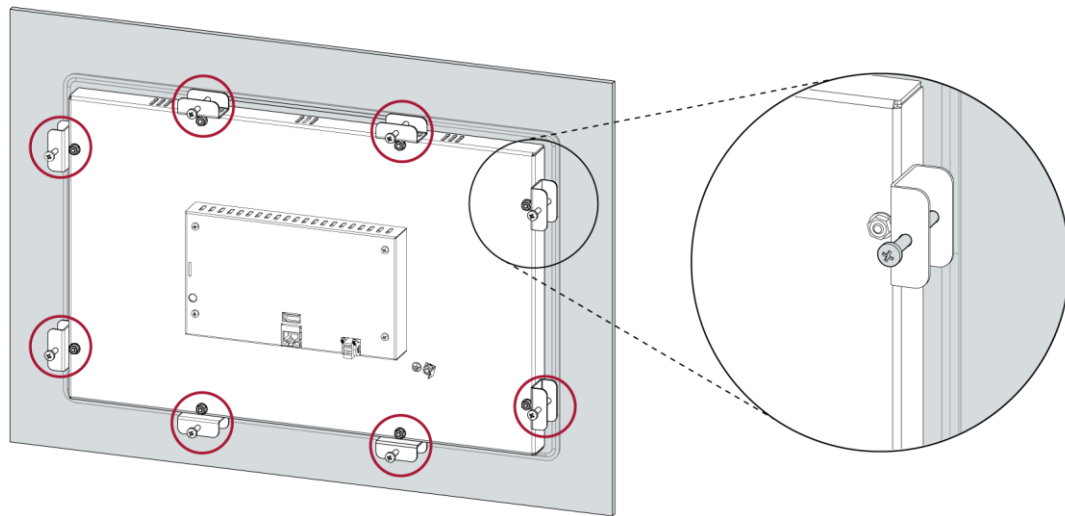

Fig. 20: Tightening the tensioning clamps

8th Hook in the remaining 6 tensioning clamps in the cover and tighten all 8 screws evenly.

## NOTICE

### Damage to the device!

If the device is mounted carelessly, it may fall out of the installation cut-out or get damaged.

- ▶ Do not tilt the device.
- ▶ Secure the device against falling down until the tensioning clamps are attached.



## 5. Connection

### WARNING

#### Uncontrolled and unpredictable operational behaviour!

The failure of certain components in electronic control systems may result in uncontrolled and unpredictable operational behaviour.

- ▶ All types of failure and the associated fuse systems are to be taken into account at system level.
- ▶ Follow the automation system manufacturer's instructions.

### 5.1. Power supply

The device is powered by an external 24 V DC power supply.

- ▶ Before plugging in the device, make sure that the external power supply meets the required specifications.

#### External power supply (24 V DC)

Supply voltage	+24 V DC SELV (-15% / +20%)
AC voltage component	Max. 5% The DC voltage level must not fall below 20.4 V.
Power consumption	Max. 1.2 A at +24 V DC
Power buffering	10 ms

#### Internal power supply

A power supply for the system electronics for an input voltage of 24 V DC (-15% / +20%) is integrated into the device. The power supply unit has built-in reverse polarity protection and surge current protection (1.2 A).

#### Installation

- ▶ All connections and cables should be set up in a way that prevents interference and capacitive interference to the device.
- ▶ Make sure that the current and voltage resistance of the supply cables are sufficient.

### 5.1.2. Connecting the power supply

**⚠ CAUTION**

**Live parts!**

- ▶ Before starting any work on the device, switch off all power supplies, including those of connected peripherals.

### 5.1.3. ET-Pro 4/7 power supply

- ▶ Connect the power supply to plug X1 (ET-Pro 4 and 7) according to the following table.



Fig. 21: ET-Pro 4/7 power supply plug X1

ET-Pro 4/7 power supply plug X1		
Pin	Des.	Assignment
11	L+ 24 V	Power supply 24 V DC (-15%/+20%) max. 1.2 A
12	GND	–

### 5.1.4. ET-Pro 10/15 power supply

- ▶ Connect the power supply to plug X100 (ET-Pro 10/15) according to the following table.

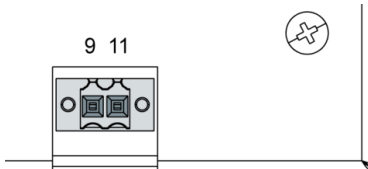

Fig. 22: ET-Pro 10/15 power supply plug X100

ET-Pro 10/15 power supply plug X100		
Pin	Des.	Assignment
9	L0+ 24 V	Power supply 24 V DC (-15%/+20%) max. 0.6 A (current peak 1.2 A)
11	GND	-

The following counterparts have been tested for the SL-SMT 3.5 plug-in connector (Weidmüller), and may be used with the device:

- BLZF 3.50/02/180 (F,LR,LH) SN

## 5.2. Data connections

### 5.2.1. Block diagram

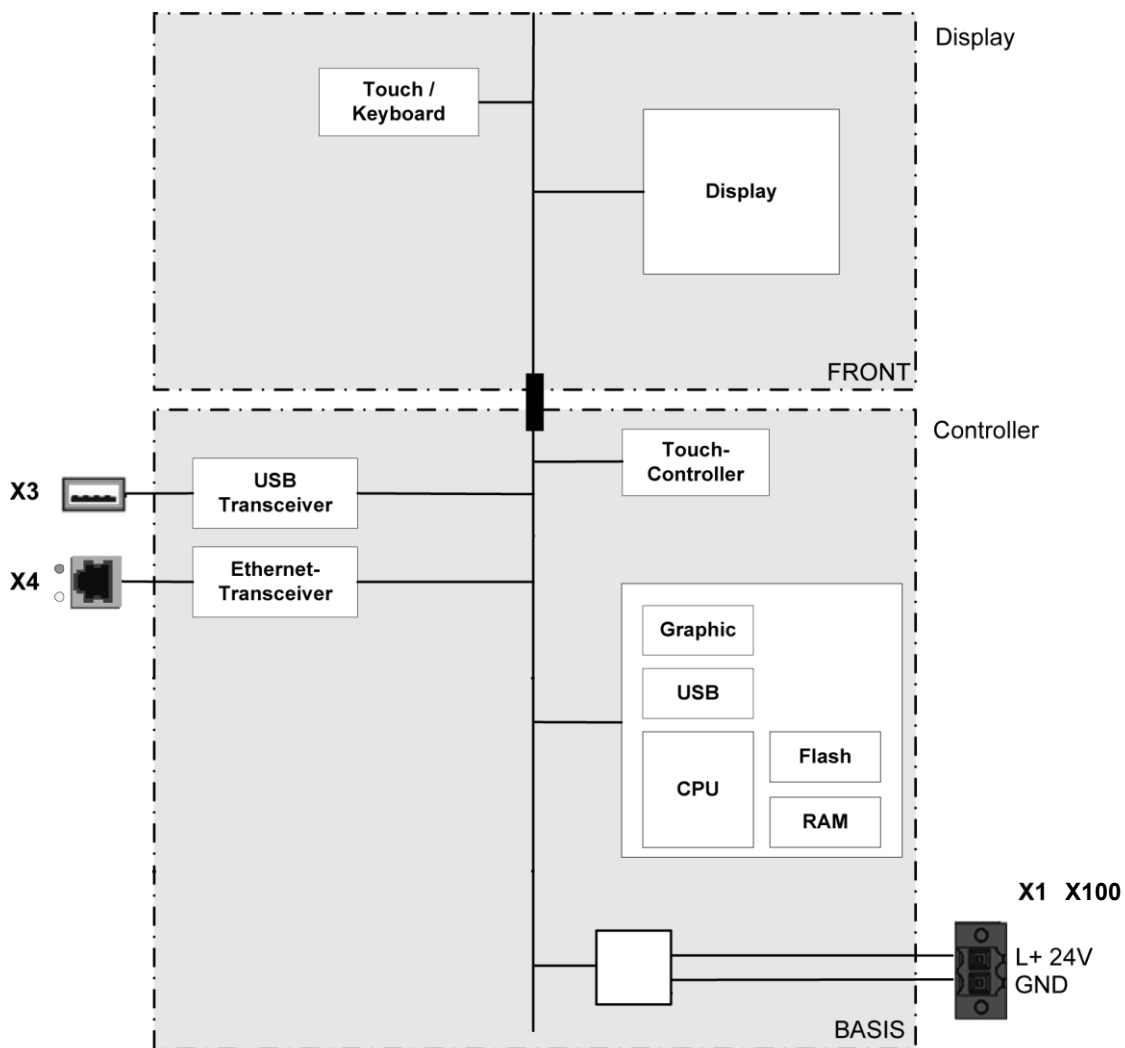

Fig. 23: Block diagram of ET-Pro

### 5.2.2. Ethernet

The onboard Ethernet adapter has one 10/100 Base-T interface with RJ-45 connection for networking. The Ethernet interface X4 can be used as a standard Ethernet interface.

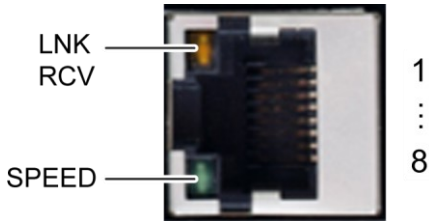

Fig. 24: Ethernet interface X4

Assignment of the Ethernet interface plug X4			
Pin	Assignment	Pin	Assignment
1	TX+	5	NC
2	TX-	6	RX-
3	RX+	7	NC
4	NC	8	NC

LEDs		
LED	Colour	Meaning according to IEEE 802.3 clause 25
LNK/RCV	Yellow	Link, Data Receive Flashing: connection active; data transfer in progress Off: no connection established
SPEED	Green	On = 100 Mbit/s Off = 10 Mbit/s

### 5.2.3. USB

Devices with a USB interface can be connected to the USB host port (Rev. 2.0). Suitable USB device classes are:  
 USB thumb drive or mouse

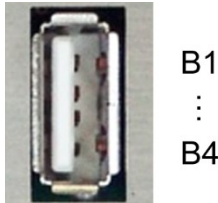

Fig. 25: USB interface X3

Assignment of the USB interface plug X3			
Pin	Assignment	Pin	Assignment
B1	VCC	B3	D+
B2	D-	B4	GND

#### NOTICE

**Damage to the USB thumb drive and malfunctions due to data loss!**

Removing a USB thumb drive while it is still in use and data is being transferred can render the USB thumb drive unusable. Open files which cannot be accessed due to removal of the USB thumb drive can block the device.

- ▶ Therefore, ensure that all data operations are complete before removing the USB thumb drive.

#### NOTICE

**Property damage and malfunctions due to data loss!**

The USB interface is protected against overload (> 0.5 A). In the event of a short-circuit during operation, the controller can trigger a system reset.

This can result in considerable damage to property and damage to the USB device.

- ▶ Before using a USB device, check its power consumption.

#### NOTICE

**Failures and malfunctions when connected directly to signal ground!**

- ▶ Only use USB devices that do not have a direct connection between the signal ground and the housing.

USB thumb drives can be inserted and removed during operation. The inserted USB thumb drive is detected automatically and appears in the Linux directory/media/usbX. When the USB thumb drive is removed, the directory /media/usbX is again removed from the directory structure.

Either the first partition on the USB thumb drive, or, if the memory is not partitioned, the entire memory will be connected, i.e. the respective directory appears automatically.

The X represents a number from 1 (first USB device) to 8 (last/max. USB device).



The mechanical design of the USB interface is designed to withstand 1,000 plugging and unplugging cycles.

---

## 6. Operation

### 6.1. Switching on and off

#### NOTICE

##### Damage or malfunction!

- ▶ Do not insert, connect, undo or touch any connections while the device is in operation.
- ▶ Before starting any work on the device, switch off all power supplies, including those to any connected peripherals (externally powered encoders, programming devices etc.).

---

#### NOTICE

##### Damage to property!

- ▶ Before connecting the power supply, ensure that all cabling and the polarity of all the connections are correct.

---

##### Switching on

The device does not have an on/off switch. The device starts automatically when the system is switched on or the power is connected.

##### Switching off

The device is switched off when the system is switched off or the power supply is disconnected.

## 6.2. Initial start-up of the network

### 6.2.1. VNC client configuration

The device must be connected to the network with the correct settings before it can be used.

#### NOTICE

##### Damage to property!

- ▶ Before connecting the power supply, ensure that all cabling and the polarity of all the connections are correct.

1st Supply power to the device (24 V).

After startup, the current network settings are shown (Server IP, IP address and net mask).

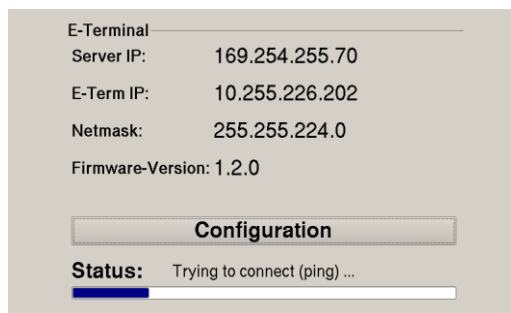

Fig. 26: Startup page and network settings

2nd Press the "Configuration" button.

A page with further information appears.

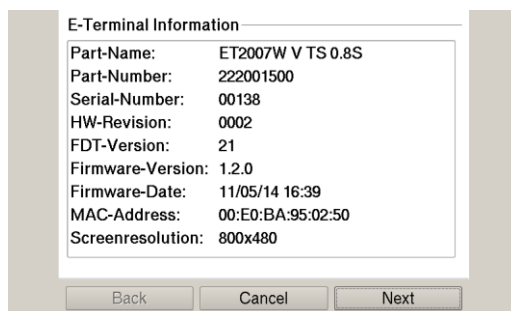

Fig. 27: Info page

3rd Press the "Next" button.

The device's Network Settings page appears.





Fig. 28: Device's network settings

4th If necessary, press the "Edit" button and change the network setting accordingly (IP address, net mask, gateway).

5th Press the "Next" button.

The page with the device's Network Settings appears.

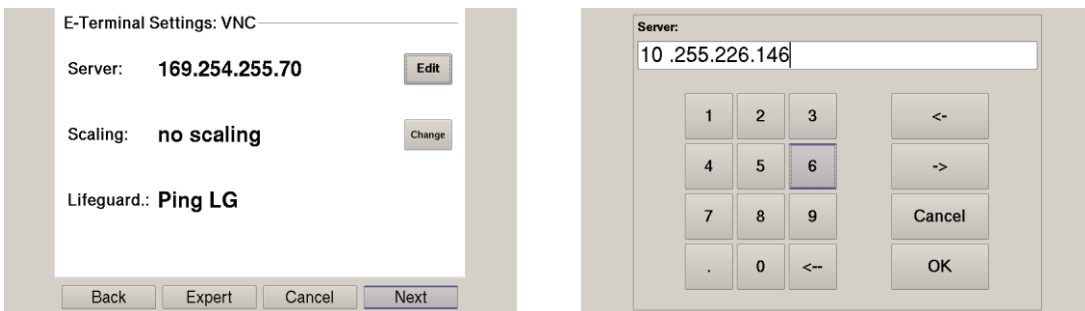

Fig. 29: Setting the server IP

6th If necessary, press the "Edit" button and change the server IP.

7th Press the "Expert" button to change the lifeguard setting.

The page with the expert settings appears.

– or –

Press the "Next" button and skip the following step.



Fig. 30: Changing the Lifeguard settings

8th Change the lifeguard setting via the "Change" button according to the version of the controller:

CODESYS V2: "Berghof VNC LG"

CODESYS V3: "Ping LG"

- 9th Skip the following pages via the “Next” button until the page with the summary of the network settings appears

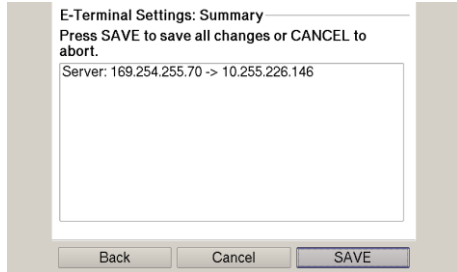

Fig. 31: Network settings summary

- 10th If no settings have been changed, press the “OK” button.  
The device’s main page appears.  
– or –  
Press the “Save” button.  
The settings are saved and the device reboots automatically.
- 11th Connect the device to the controller using a network cable.

The device is configured and ready for use.

## 6.2.2. Web terminal configuration

The device must be connected to the network with the correct settings before it can be used in Web Terminal mode. To do so, please read section 6.2.1 VNC client configuration, steps 3 and 4.

- 12th Supply power to the device (24 V).  
After startup, the current network settings are shown (Server IP, IP address and net mask).
- 13th Press the “Configuration” button and then the “Next” button.  
The device’s Network Settings page appears.
- 14th Press the “Expert” button and press the “Change” button to change the device to Web Terminal mode.

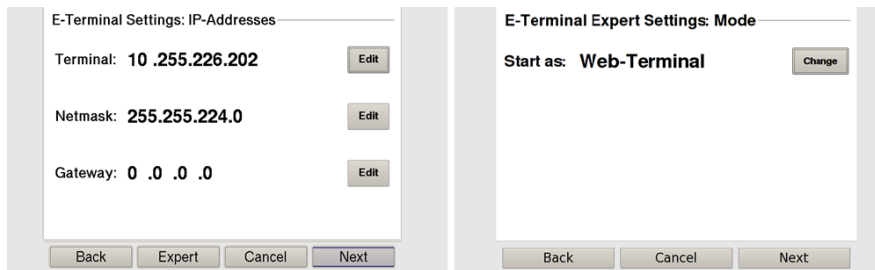

Fig. 32: Changing to Web Terminal mode

- 15th Skip the following pages via the “Next” button until the page with the summary of the settings performed appears.
- 16th Press the “Save” button. The settings are saved and the device reboots automatically.  
After reboot, the device is in Web Terminal mode.



The “Configuration” button can only be selected a short time after the start. After a few seconds, the device starts the integrated browser and blocks the “Configuration” button.

To access the configuration menu, in this case, you must reboot the device.

17th Press the “Configuration” button directly after the booting up.

18th Skip the IP settings pages via the “Next” button until the page with the Visu-URL appears.

19th Press the “Edit” button.

20th Enter the required URL and confirm with the “OK” button.

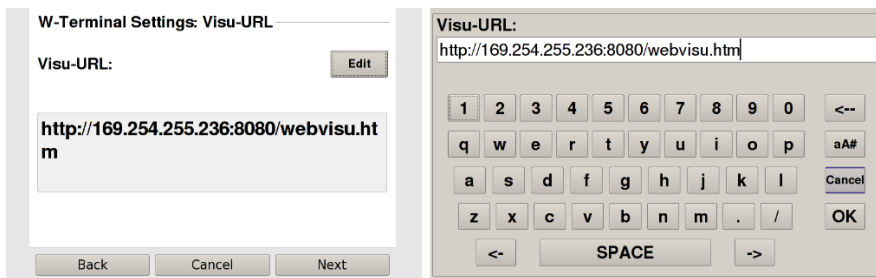

Fig. 33: Setting the Visu-URL

21st Skip the following pages via the “Next” button until the page with the summary of the settings performed appears.

22nd Press the “Save” button.

The settings are saved and the device reboots automatically.

After reboot, the integrated browser starts automatically after a few seconds and loads the set Visu-URL.

## 6.3. Operation

### 6.3.1. Status indicators

The status indicator function is dependent on the software development environment used in conjunction with the device.

The operating status LEDs show the current status of the power supply, the module mode and any error messages.

The LEDs of the ET-Pro series are controlled by the firmware.

#### Location of the operating status LEDs

The Run/Stop and Error LEDs display the system status.

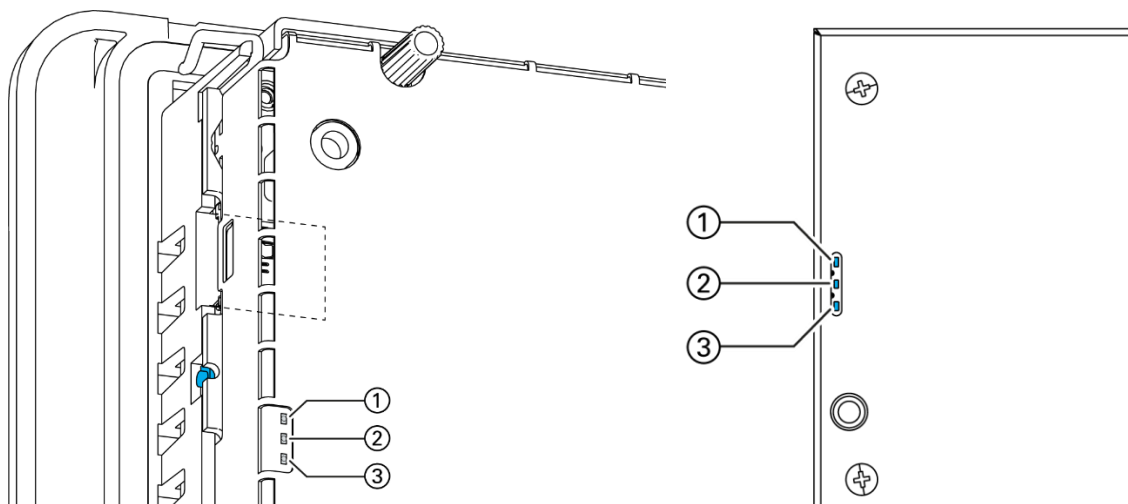

Fig. 34: Location of the operating status LEDs on ET-Pro 4/7 (left) and ET-Pro 10/15 (right)

LED	Meaning
1 PWR (green)	Shows that the power supply to the module electronics is correct.
2 Run/Stop (yellow/green/red)	Shows the system statuses.
3 Error (red)	Shows that the device has been stopped due to an error.

#### Meaning of the LED displays

System statuses are shown using flashing signals on the Run/Stop LED in yellow.

CODESYS operating statuses are shown via continuous illumination of the Run/Stop LED as either red or green.

While the Run/Stop light is flashing yellow: the device is in use and must not be switched off.

During the boot process, the device does not give any warnings via the LEDs.

### 6.3.2. microSD card

#### **WARNING**

**Serious injury as a result of uncontrolled and unpredictable operational behaviour!**

Inserting or removing the microSD card can result in the device malfunctioning. The failure of electronic control systems may result in uncontrolled and unpredictable operational behaviour.

- ▶ Insert or remove a microSD card only when the device is switched off.
- 

The ET-Pro series does not support the functions of the microSD interface.



The operating life of the gold-plated contacts is up to 10,000 plugging and unplugging cycles.  
The microSD card drive has a push-in/push-out insertion and ejection mechanism.  
To avoid malfunction, the microSD card may not be removed by pulling.

## 6.4. Troubleshooting

### 6.4.1. No network connection

- ▶ Check the wiring/switch.
- ▶ Check whether an IP address has been assigned twice.
- ▶ Check the network settings on the PC: the subnet and subnet mask must match the settings in the controller.
- ▶ Check firewall/anti-virus programs on the PC.
- ▶ Check the Lifeguard setting.

---

## 7. Servicing / Maintenance

Repairs and corrective maintenance may only be carried out by the manufacturer or its authorised customer service centres.

### 7.1. Maintenance

#### **WARNING**

##### **Uncontrolled and unpredictable operational behaviour!**

Failures or malfunctions may result in uncontrolled and unpredictable operational behaviour.

- ▶ Do not insert, connect, undo or touch any connections while the device is in operation.
- ▶ Before starting any work on the device, switch off all power supplies, including those to any connected peripherals (externally powered encoders, programming devices etc.).

---

If the device is used correctly it should not require maintenance.

- ▶ Make sure all the ventilation openings are kept free of obstructions
- ▶ Do not open the device. If it is necessary to work in the device, contact the Service department.

## 7.2. Cleaning

### NOTICE

#### **Damage to the front panel!**

The front panel is made of glass and must not be exposed to any mechanical or chemical stress.

- ▶ Do not use any high-pressure cleaners or steam jets.
- ▶ Do not use any corrosive cleaning products, thinners, abrasive media or hard objects to clean it.
- ▶ Do not apply any undue force to the front face.

- 
- ▶ To avoid faults due to inadvertent activation, switch the device off before cleaning the front panel.
  - ▶ Only clean surfaces using a dry, lint-free cloth.

## 7.3. Chemical resistance

### 7.3.1. Resistance of the touch screen

The active area of the touch screen is resistant to the following chemicals when exposed to them for a period of up to an hour at a temperature of max. 21 °C:

#### **Domestic and industrial chemicals**

Detergent, all-purpose cleaners, washing-up liquid, glass cleaner, hydrogen peroxide (3%), Lysol, ethanol, isopropanol, acetone, methyl ethyl ketone, toluene, concentrated hydrochloric acid, petroleum, White spirit, petrol, engine oil, diesel, gear oil, brake fluid, anti-freeze, Hydraulic oil

#### **Condiments**

Lemon juice, tomato juice, mustard, tomato ketchup

### 7.3.2. Resistance of the front membrane display

#### NOTICE

##### Damage to the front membrane display!

The front membrane display is not resistant to the following chemicals or influences, and can be damaged by their effects:

Benzyl alcohol  
 Concentrated alkalis  
 Concentrated inorganic acids  
 Dichloromethane (methylene chloride)  
 High-pressure steam above 100°C  
 Long-term effects of direct sunlight

- ▶ Keep these substances away from the front membrane display.
- ▶ Protect the display against direct sunlight.

The front membrane display (Autoflex EB) is based on a polyester membrane with biaxial alignment. It is highly resistant to solvents.

The front membrane display is resistant to the following chemicals in accordance with standard DIN 42 115 part 2, without any evident change or damage:

##### Application of more than 24 hours

1,1,1 trichloroethane, aliphatic hydrocarbons, benzene, cyclohexanol  
 diethyl ether, ethanol

Acetaldehyde, acetone, acetic acid < 50%, sulphuric acid 30%, diacetone alcohol, 1.4 dioxane  
 DS2 decontamination fluid, fabric conditioner

Acetonitrile, alkali carbonate, ammonia < 32%, sal ammoniac < 10%, bichromate, caustic potash (potassium hydroxide) < 2%

Sodium hydroxide 50%, refrigerant (Hysol X), diesel oil, castor oil, silver nitrate 20%, ethyl acetate  
 Acetaldehyde, fluorochlorinated hydrocarbons, glycerine, isopropanol, methanol, ferric chloride < 30%  
 Formic acid (methane acid) < 50%, hydrochloric acid < 10%, hydrogen peroxide < 25%, isophorone,  
 methyl ethyl ketone (butanone), nitric acid < 10%, Tetrahydrofuran, formaldehyde (37%) in water

Linseed oil, paraffin oil, petrol, silicone oil, turpentine substitute, universal brake fluid (e.g. Castrol Girling), dibasic ester 6, Skydrol 500B4, Lixtop, potassium ferrocyanide

Tetrachloroethylene (perchloro ethylene), toluene, triacetin, trichloroethylene, xylene

Phosphoric acid < 30%, potash, sodium hypochlorite < 20%, sulphuric acid < 10%,  
 detergent, saturated seawater solution

##### Application of 24 hours at 50°C

Top Job, Jet Dry, Gumption, Fantastic, Formula 409, grape juice, milk, Ariel, Persil, Wisk, Lenor,  
 Downey, Ajax, Vim, Domestos, Vortex, Windex

##### Application of less than 1 hour

Glacial acetic acid (pure acetic acid)



## 8. Disassembly

- 1st Disconnect the device and associated peripherals from the power supply.
- 2nd Unplug all plugs and cables.

### NOTICE

#### Damage to the device!

If the device is disassembled carelessly, it may fall out of the installation cut-out or get damaged.

- ▶ Do not tilt the device.
- ▶ Secure the device to prevent it from falling, particularly when removing it from the control cabinet.

### 8.1. ET-Pro 4/7 disassembly

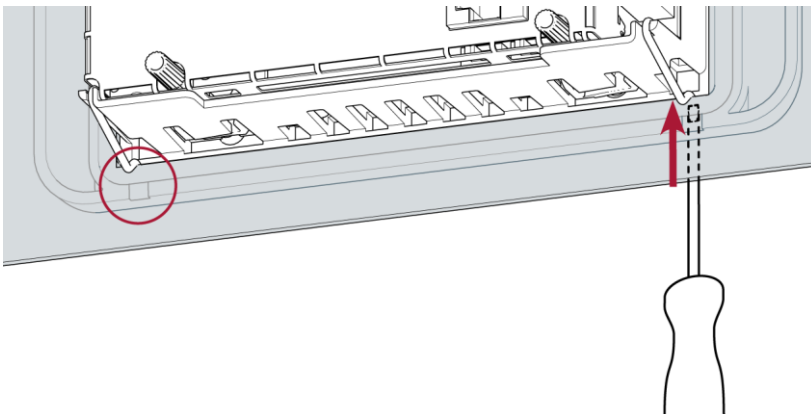

Fig. 35: Loosening the fastening clips

- 3rd Device with twist-lock catches: Using a T9x50 screwdriver, fully open the twist-lock catches and turn them anti-clockwise to the stop.
- 4th Using a slotted screwdriver (blade 3–3.5 mm), undo the fastening clips.  
ET-Pro 4: 4 fastening clips (2 at the bottom, 2 at the top)  
ET-Pro 6: 6 fastening clips (3 at the bottom, 3 at the top)
- 5th Push the device sufficiently far out of the installation cut-out that the fastening clips are no longer engaged.

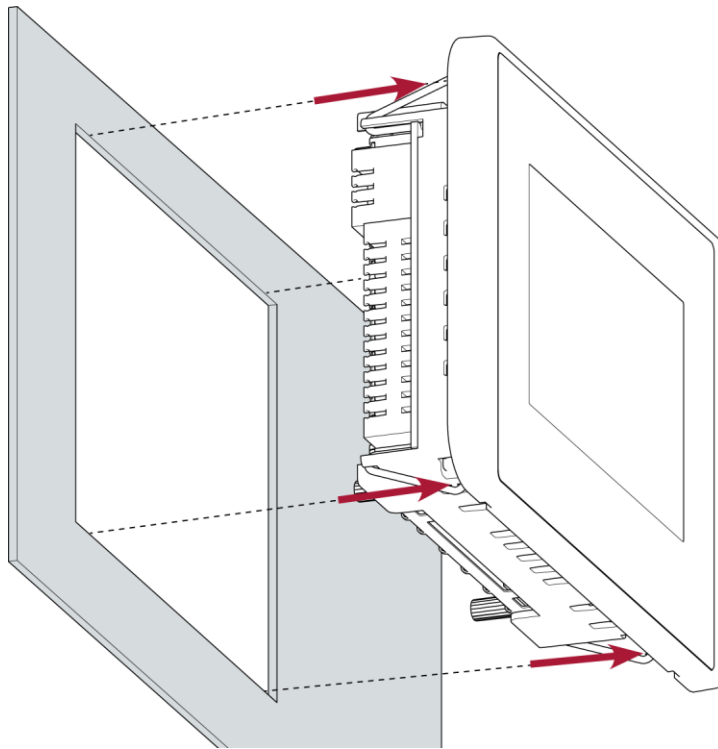

Fig. 36: Pushing the device out of the installation cut-out

6th Push the device evenly forwards out of the installation cut-out.

## 8.2. ET-Pro 10/15 disassembly

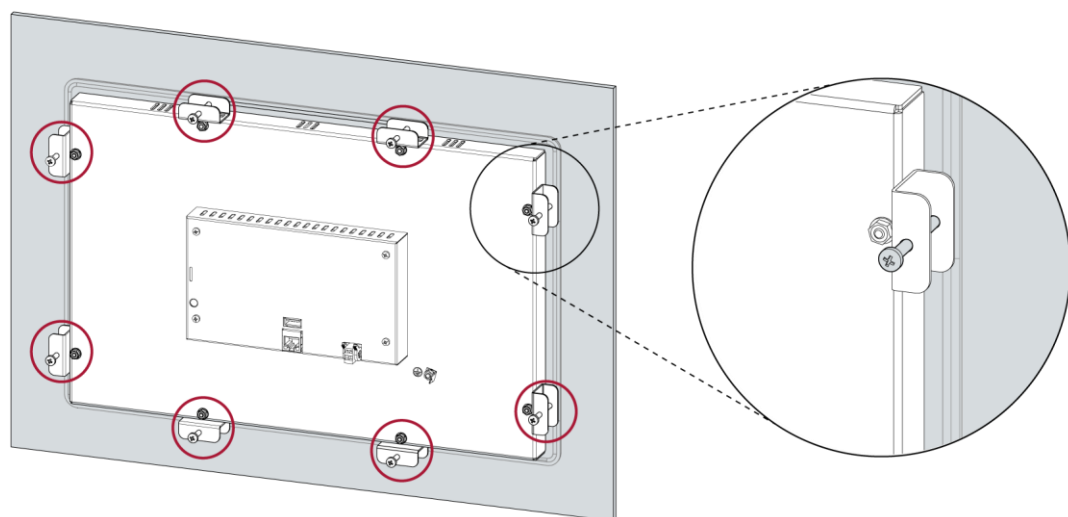

Fig. 37: Loosening the screws

3rd Loosen the screws of the 8 tensioning clamps evenly.

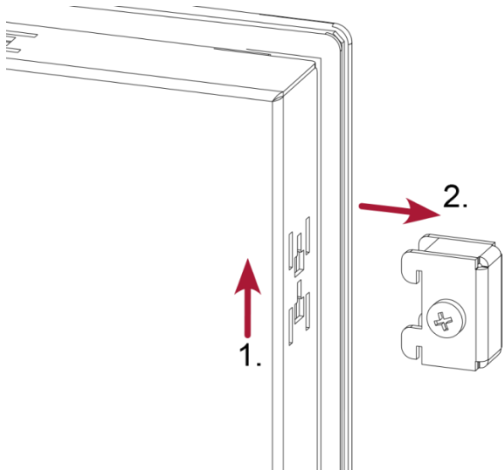

Fig. 38: Removing the tensioning clamps

4th Remove the 8 tensioning clamps.

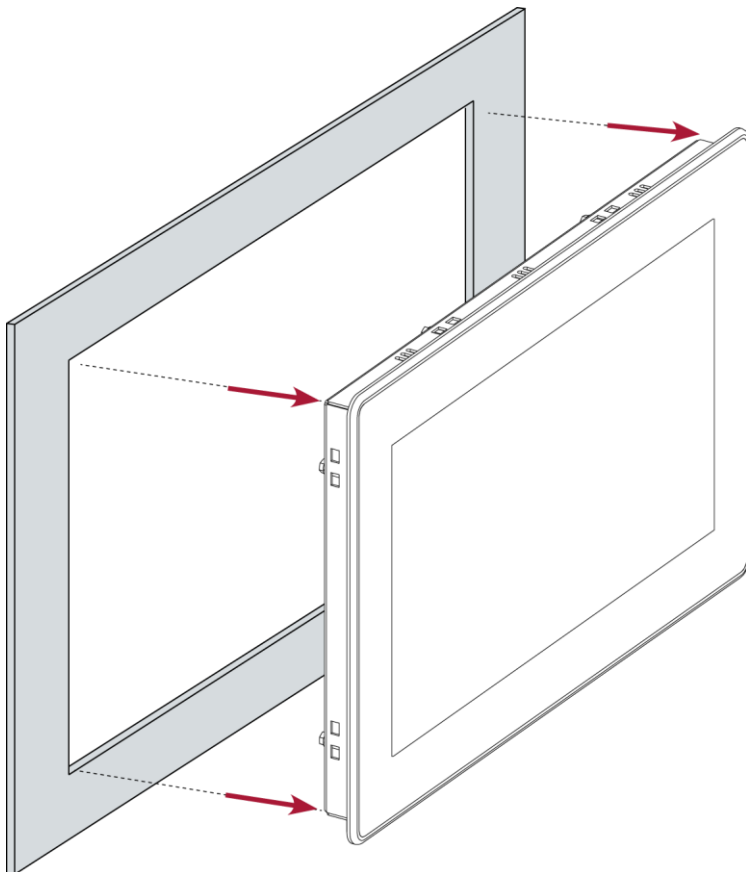

Fig. 39: Pushing the device out of the installation cut-out

5th Push the device evenly forwards out of the installation cut-out.

## 8.3. Disposal

The device contains the following components which need to be disposed of separately:

- Metals
- Electronic components
- Battery

The respective national regulations for the disposal of electrical appliances in B2B business apply.

The following options are available for disposal of the device:

### **Disposal by the manufacturer**

Unless otherwise agreed, the devices can be returned for disposal.

### **Disposal in accordance with regional regulations**

- ▶ Dismantle the device and disassemble it completely into its component parts.
- ▶ Send the metal parts for metal recycling.
- ▶ Sort the electronic parts (circuit boards, drives, etc.).
- ▶ Dispose of electronic scrap in accordance with the national laws and regulations.
- ▶ Make sure that the battery is completely discharged.
- ▶ Dispose of batteries at a recognised collection point in accordance with national laws and regulations.

## 9. Information and options

B-Primis Ethernet Terminal	ET-Pro 4	ET-Pro 7	ET-Pro 10	ET-Pro 15
<b>Display</b>				
Display	WQVGA	WVGA	WXGA	WXGA
Diagonals	4.3"	7"	10.1"	15.6"
Item no.	S-01010202-0101 S-01010202-0201	S-01010202-0104 S-01010202-0204	S-01010202-0105 S-01010202-0205	S-01010202-0108 S-01010202-0208
Resolution	480 x 272 pixels	800 x 480 pixels	1280 x 800 pixels	1366 x 768 pixels
Colours	TFT: 16.7 M (24 bits/pixels)			
<b>CPU, user memory</b>				
CPU	800 MHz ARM® CPU with Cortex™-A9 single core			
Program memory (flash)	512 MB		2 GB	
data memory (RAM)	512 MB			
<b>Dimensions and weights</b>				
Dimensions (WxHxD)	161 x 103 x 46 mm	224 x 152 x 46 mm	283 x 198 x 55	425 x 280 x 55 mm
Weight	approx. 450 g	approx. 600 g	2.5 kg	approx. 3 kg
<b>Operating conditions</b>				
Ambient temperature	0°C to 55°C (front and rear side of device, in compliance with installation requirements)			
Relative humidity	max. 85%, non-condensing			

<b>Transport and storage</b>			
Ambient temperature	-20°C to +70°C		
Relative humidity	max. 85%, non-condensing		
<b>Operation</b>			
Installation	Integrated securing clips	Bolt mounting, tensioning clamps for IP65	Removeable tensioning clamps
Certification	CE (EN 61131-2) cUL <sub>us</sub> (UL 61010-2-201)	CE (EN 61131-2)	CE (EN 61131-2) cUL <sub>us</sub> (UL 61010-2-201)
Touch operation	Resistive		
<b>Shock resistance</b>			
Vibration	sinusoidal (EN 60068-2-6) test: Fc 10-150 Hz, 10 m/s <sup>2</sup>		
Shock	15 G (approx. 150 m/s <sup>2</sup> ), 11 ms duration, half-sine (EN 60068-2-27) Test: Ea		
<b>EMC, protection rating</b>			
Emission standard	EN 61000-6-3, living area	EN 61000-6-4, industrial area	
Resistance to interference	EN 61000-6-2, industrial area	EN 61000-6-2, industrial area	
Protection class	III		
Isolation protection	EN 61131-2; 500 VDC test voltage		
Protection rating	IP20, front IP54 (IP65 only with twist locks catches tight-end)	IP20, front IP54 (IP65 only with all tensioning clamps attached)	
Front membrane	Autoflex		
Outdoor use	Like all polyester-based membranes, Autoflex is unsuitable for long-term exposure to direct sunlight.		

<b>Power supply (24 V power supply unit)</b>	
Supply voltage	+24 VDC (-15% / +20%) SELV max. AC voltage component 5%
Power consumption	typ. 0.3 A, max. 1.2 A at +24 VDC
Protection against reverse polarity	Yes
<b>Ethernet interface</b>	
No. / type of interface	1x 10/100 Base T
Connection system	RJ45
Protocols	TCP/IP
<b>USB interface</b>	
No. / type of interface	1x host USB 2.0 / USB plug type A
No. plugging/unplugging cycles	max. 1,000
<b>Additional functions</b>	
microSD card slot	no function

## 9.1. Type plate

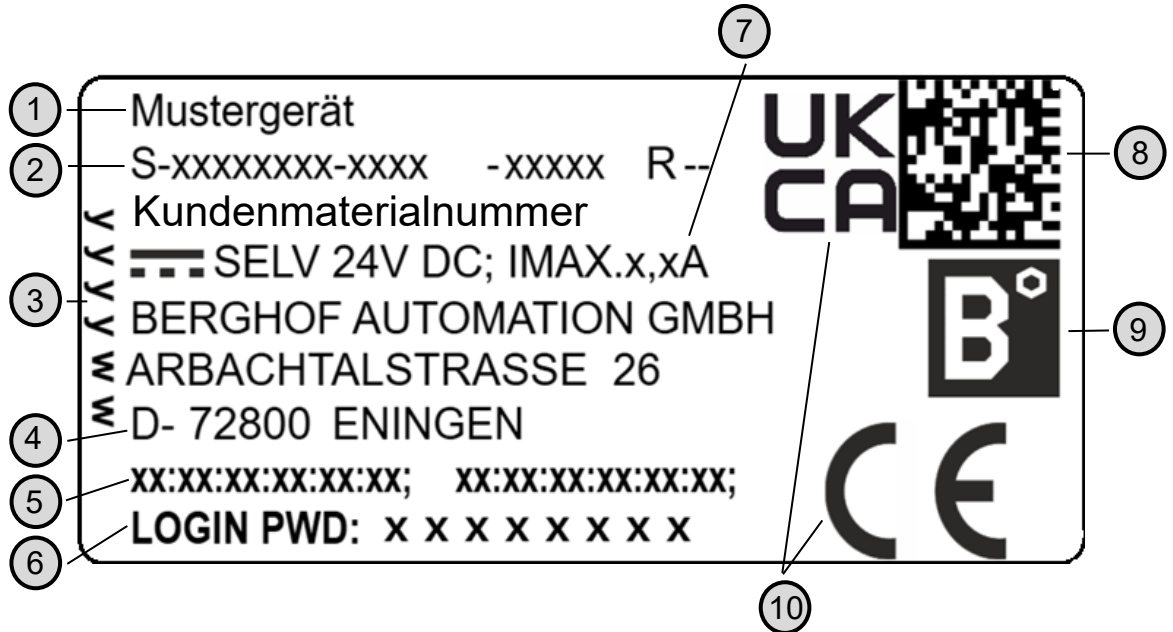

Fig. 40: Type plate

No.	Designation	No.	Designation
1	Product description	6	Default password
2	Order no. / serial no. / Version identification	7	Supply voltage and maximum current
3	Production date (year/week)	8	QR code (identification no.)
4	Manufacturer (manufacturer's address)	9	Manufacturer's logo
5	MAC addresses of the unit	10	Conformity marking



## 9.2. Device variants and identification

Designation	Order number	Features
<b>ET-Pro 4 S01</b>	S-01010202-0101	4.3" display + VNC
<b>ET-Pro 4 S02</b>	S-01010202-0201	+ Web Visu (web client, HTML5)
<b>ET-Pro 7 S01</b>	S-01010202-0104	7" display
<b>ET-Pro 7 S02</b>	S-01010202-0204	+ Web Visu (web client, HTML5)
<b>ET-Pro 10 S01</b>	S-01010202-0105	10.1" display + VNC
<b>ET-Pro 10 S02</b>	S-01010202-0205	+ Web Visu (web client, HTML5)
<b>ET-Pro 15 S01</b>	S-01010202-0108	15.6" display + VNC
<b>ET-Pro 15 S02</b>	S-01010202-0208	+ Web Visu (web client, HTML5)

## 9.3. Options and extensions

Options are ordered via the combination  
 "Order number option1 option2..."

e.g.: **S-01010104-0204 S001 S002 H001**

In addition to the order number, additional extensions in the form of hardware, software options are marked as follows:

Option code	Option type
<b>S000-S999</b>	Software options e.g. field buses
<b>H000-H999</b>	Hardware options e.g. plug kit, certifications
<b>C000-C999</b>	Customised options e.g. customised firmware, customised front membrane display

The following extensions are possible for the ET-Pro:

Option	Designation	Option type
<b>H001</b>	Plug kit (Weidmüller BLZF 3.50/02/180)	Hardware
<b>H100</b>	UL-certified	

For more detailed and up-to-date information about the options available for this device, please refer to the product catalogue or website.

The additional features included or installed in each device are listed on the options label. This label can be found on the device and/or on the packaging.



Fig. 41: Options label

## 10. Standards and certificates

### 10.1. Standards

#### Applicable directives

- EMC Directive 2014/30/EU
- RoHS Directive 2011/65/EU

#### Applicable standards

- Standard  
EN 50581:2012
- PLC standard  
EN 61131-2:2008-4
- Emission standard  
EN 61000-6-3:2012-11
- Safety provisions  
DIN EN 61010-2-201

## 10.2. Declaration of conformity/Technical data

The declarations of conformity, technical data and further information can be found on our website at:

<https://www.berghof-automation.com/en/downloads>

Select the appropriate area (automation technology) and complete the form. Information on data protection can also be found on the page.

The technical data for ET Pro 4 / 7 / 10 / 15 can be found in the operating panels category.

If a document is missing, it can be requested via our contact form at

<https://www.berghof-automation.com/en/contact>

## 11. Customer services / addresses

Repairs and corrective maintenance may only be carried out by the manufacturer or its authorised customer service centres.

### 11.1. Customer services

Berghof Automation GmbH  
Arbachtalstrasse 26  
72800 Eningen  
Germany  
T +49.7121.894-183  
F +49.7121.894-100  
email: [support-controls@berghof.com](mailto:support-controls@berghof.com)  
[www.berghof-automation.com](http://www.berghof-automation.com)

### 11.2. Repair service

Please send the goods to the Berghof repair service for repairs, stating the RMA number and a detailed description of the fault..

Berghof Automation GmbH  
BU Automatisierungstechnik  
Reparaturservice  
Arbachtalstrasse 26  
72800 Eningen

You can request the RMA number at:  
[www.berghof-reparaturservice.com](http://www.berghof-reparaturservice.com)

## 11.3. Addresses

CAN in Automation; international manufacturer and user organisation for CAN users in automation:

CAN in Automation e.V. (CiA)

Am Weichselgarten 26

91058 Erlangen, Germany

headquarters@can-cia.de

www.can-cia.de

EtherCAT Technology Group

ETG Headquarters

Ostendstraße 196

90482 Nuremberg, Germany

info@ethercat.org

www.ethercat.org

Beuth Verlag GmbH, 10772 Berlin, Germany

or

VDE-Verlag GmbH, 10625 Berlin, Germany

VDE Verlag GmbH, 10625 Berlin, Germany

or

Internet research: [www.iec.ch](http://www.iec.ch)

## 12. Appendix

### 12.1. Notes on copyright and the software licence

The device's firmware contains free software. Parts of this software are available under the following and other open source licences:

- GNU General Public License (GPL)
- GNU Lesser General Public License (LGPL)
- Mozilla Public License (MPL)
- FreeType License (FTL)

The source code for the free software can be requested from Berghof Customer Services at cost price within three years of delivery of the device.

### 12.2. List of figures

Fig. 1: Overview of ET-Pro 4 (rear) .....	15
Fig. 2: ET-Pro 7 (at the rear) .....	16
Fig. 3: ET-Pro 10/15 (rear) .....	17
Fig. 4: ET-Pro 4 dimensions .....	19
Fig. 5: ET-Pro 4 installation cut-out .....	20
Fig. 6: ET-Pro 7 dimensions .....	21
Fig. 7: ET-Pro 7 installation cut-out .....	22
Fig. 8: ET-Pro 10 dimensions .....	23
Fig. 9: ET-Pro 10 installation cut-out .....	24
Fig. 10: ET-Pro 15 dimensions .....	25
Fig. 11: ET-Pro 15 installation cut-out .....	26
Fig. 12: Opening the twist-lock catches .....	27
Fig. 13: Installation in an installation cut-out, example with 4 fastening clips .....	27
Fig. 14: Device clipped into place in the installation cut-out, example with 4 fastening clips .....	28
Fig. 15: Installing in the installation cut-out .....	29
Fig. 16: Hooking in the tensioning clamps (at the rear) .....	30
Fig. 17: Tightening the tensioning clamps .....	30
Fig. 18: Installing in the installation cut-out .....	31
Fig. 19: Hooking in the tensioning clamps (at the rear) .....	31
Fig. 20: Tightening the tensioning clamps .....	32
Fig. 21: ET-Pro 4/7 power supply plug X1 .....	34
Fig. 22: ET-Pro 10/15 power supply plug X100 .....	35
Fig. 23: Block diagram of ET-Pro .....	36
Fig. 24: Ethernet interface X4 .....	37
Fig. 25: USB interface X3 .....	38
Fig. 26: Startup page and network settings .....	40
Fig. 27: Info page .....	40
Fig. 28: Device's network settings .....	41
Fig. 29: Setting the server IP .....	41
Fig. 30: Changing the Lifeguard settings .....	41
Fig. 31: Network settings summary .....	42
Fig. 32: Changing to Web Terminal mode .....	42

Fig. 33: Setting the Visu-URL..... 43

Fig. 34: Location of the operating status LEDs on ET-Pro 4/7 (left) and ET-Pro 10/15 (right) ..... 44

Fig. 35: Loosening the fastening clips ..... 49

Fig. 36: Pushing the device out of the installation cut-out ..... 50

Fig. 37: Loosening the screws..... 50

Fig. 38: Removing the tensioning clamps ..... 51

Fig. 39: Pushing the device out of the installation cut-out ..... 51

Fig. 40: Type plate..... 56

Fig. 41: Options label ..... 58