

B-PRIMIS ET-PRIME Series



Copyright © Berghof Automation GmbH

Reproduction and duplication of this document and utilisation and communication of its content is prohibited unless with our express permission. All rights reserved.

Infringements will result in compensation for damages.

Legal disclaimer

The content of this document has been verified for conformity with the hardware and software described therein. It is, however, impossible to rule out all variations. As a result, we cannot be held responsible if the content is not fully compliant. The information given in this document is updated regularly and any corrections will be reflected in future versions. We are always willing to receive suggestions for improvements. Subject to technical modifications.

Trademarks

- CANtrol@// is a registered trademark belonging to Berghof Automation GmbH.
- Microsoft®, Windows® and the Windows® logo are registered trademarks belonging to the Microsoft Corp. in the USA and in other countries.
- EtherCAT® is a registered trademark and patented technology licensed from Beckhoff Automation GmbH, Germany.
- CiA® and CANopen® are registered trademarks belonging to CAN in Automation e. V.
- ARM ® and Cortex ® are registered trademarks belonging to ARM Limited.
- PROFINET® is a registered trademark belonging to PROFIBUS Nutzerorganisation e. V.
- Modbus® is a registered trademark belonging to the Modbus-IDA Organisation.
- i.MX6 is a registered trademark belonging to NXP Semiconductors.

The rights of all companies and company names as well as products and product names mentioned in this website belong to the respective companies.

Notes on this user manual

This device user manual contains information which is specific to the product and which is valid at the time of printing.

This manual is only complete in conjunction with the product-related hardware and software user manuals required for the individual application.

You can reach us at:

Berghof Automation GmbH

Arbachtalstrasse 26

72800 Eningen

Germany

T +49.7121.894-0

F +49.7121.894-100

E-mail: controls@berghof.com

<https://www.berghof-automation.com>

Berghof Automation GmbH is certified to DIN EN ISO 9001:2015.

Change log

Version	Date	Description
0.1	11.02.2020	first draft with new format and new numbers
0.9	05.06.2020	Prerelease
1.0	18.06.2020	Formatting of the document revised
1.1	13.10.2020	Address correction
1.2	20.11.2023	Adaption Cybersecurity, RMA-Process, 2-pin plug for power supply ET-Prime 10/15 added

Table of contents

1.	GENERAL INFORMATION	7
1.1.	Notes on the manual	7
1.2.	Symbols and visual depictions.....	8
1.3.	Hazard categories and indications.....	8
1.4.	Qualified personnel.....	9
1.5.	Duty of care.....	9
1.5.1.	General.....	9
1.6.	Intended use	10
1.7.	Transport and storage	11
	Transport and storage	11
	Devices with batteries/rechargeable batteries	11
	Operation.....	11
1.8.	Unpacking	11
2.	SAFETY	12
2.1.	Safety related systems	12
2.2.	Safety instructions	12
	Working on the device.....	13
2.3.	Cybersecurity	13
3.	PRODUCT DESCRIPTION	14
3.1.	Overview ET-Prime 7/10/15	15
3.2.	Scope of delivery and accessories	16
	Scope of delivery.....	16
	Accessories	16
3.3.	Product features.....	16
	Installation	16
	Processor	16
	Ethernet interface	16
	USB interface	16
	Summary of features	16
4.	INSTALLATION	17
4.1.	Preparation for front installation ET-Prime 7	17
4.2.	Preparation for front installation ET-Prime 10	19
4.3.	Preparation for front installation ET-Prime 15	21
4.4.	Assembly	23

5.	CONNECTION	25
5.1.	Power supply	25
	Internal power supply	25
	Installation	25
5.1.1.	Connecting the power supply	26
	B-Primis ET Prime 10/15	26
	B-Primis ET Prime 7	27
5.2.	Data connections	28
5.2.1.	Block circuit diagram	28
5.2.2.	Ethernet interface (X4)	29
5.2.3.	USB interface	30
6.	OPERATION	31
6.1.	Switching on and off	31
	Switching on	31
	Switching off	31
6.2.	Initial Setup of the device	32
6.2.1.	Configuration	32
6.2.2.	Web Terminal	34
6.3.	Status indicators	36
6.4.	microSD-Card	37
6.5.	Troubleshooting	37
6.5.1.	No network connection	37
7.	MAINTENANCE AND SERVICE	38
7.1.	Maintenance	38
7.2.	Cleaning	38
8.	UNINSTALLATION	39
9.	DISPOSAL	41
10.	INFORMATION AND OPTIONS	42
10.1.	Nameplate	44
10.2.	Device variations and identification	45
10.3.	Options and Extensions	46
11.	STANDARDS AND CERTIFICATES	47
11.1.	Standards	47
	Applicable directives	47
	Applicable standards	47
11.2.	Declaration of conformity/Technical data	47

12. CUSTOMER SERVICES / ADDRESSES	48
12.1. Customer service	48
12.2. Repair service	48
12.3. Addresses	49
13. APPENDIX	50
13.1. Information on copyright and software licence	50
13.2. List of figures	50

1. General information

This user manual is intended for use by qualified professionals and contains information on the assembly, installation, start-up and maintenance of the device.

1.1. Notes on the manual

This manual is a component of the product and applies to the following devices:

- B-Primis ET-Prime 7
- B-Primis ET-Prime 10
- B-Primis ET-Prime 15

The manual contains information on the following topics:

- Applications
- Safety
- Mechanical design
- Electrical design
- Connections
- Start-up
- Upkeep and maintenance
- Decommissioning
- Disposal

- ▶ Always keep this user handbook available alongside the product.

1.2. Symbols and visual depictions

The following symbols and visual depictions are used in this handbook:

Symbol	Meaning
→ ...	List entry
▶ ...	Individual instruction or list of instructions which can be carried out in any order.
1. ... 2. ...	List of instructions which must be carried out in the order given.
	Additional product information

Design of warnings:

 WARNING

Optional: **Hazard type and source**
 Other Short description and consequences
 Symbols ▶ Preventive measures

1.3. Hazard categories and indications

The following indications are used in the case of warning messages so as to ensure your personal safety and avoid any damage to property.

The indications have the following meanings:

 DANGER

Serious injury or death
 Non-compliance with the safety features will result in death or serious injury.
 ▶ Take preventive measures.

 WARNING

Possible serious injury or death
 Non-compliance with the safety features may result in death or serious injury.
 ▶ Take preventive measures.

⚠ CAUTION

Possible minor injuries

Non-compliance with the safety features may result in minor injuries.

- ▶ Take preventive measures.

NOTE

Possible damage to property

Non-compliance with the safety features may result in damage to property.

- ▶ Take preventive measures.

1.4. Qualified personnel

The installation, start-up and maintenance of the device must be carried out by qualified personnel.

For the purposes of this documentation and the safety instructions contained therein, “qualified personnel” means trained staff who are familiar with safety concepts in automation engineering and who are authorised to assemble, install, start up, earth and identify devices, systems and electrical circuits in accordance with standards set in safety engineering.

1.5. Duty of care

1.5.1. General

The user (OEM) must ensure the following:

- The device must only be used according to regulations.
- The device must only be used in good working order.
- The user handbook must always be kept legible and fully available.
- Only sufficiently qualified and authorised personnel may carry out the assembly, installation, start-up and maintenance of the device.
- These authorised personnel must receive regular training on all relevant occupational health and safety and environmental protection issues and must be fully familiar with the contents of this user handbook, particularly the sections regarding safety features.
- Any markings or identification labels and safety and warning signs on the device must not be removed and must be kept legible at all times.
- The national and international regulations regarding the operating of machinery and facilities where the device is being used must be observed at all times.
- The user must always be kept abreast of any current relevant information regarding the device and its use or operation.

The user takes direct responsibility for agreeing with the competent authorities the use of safety-related control components, and for compliance with their instructions

1.6. Intended use

The device is part of a modular automation system for industrial control applications within the medium to high performance range. It extends the communications capabilities to include EtherCAT, Profinet, Modbus and others.

The automation system is designed for use within overvoltage category I (IEC 364 4 443) systems for controlling and regulating machinery and industrial processes in low-voltage installations in accordance with the following general parameters:

- maximum rated supply voltage of 1,000 V AC (50/60 Hz) or 1,500 V DC
- Environment with maximum category 2 pollution (EN 61010-1)
- for use up to a maximum altitude of 2,000 m above msn.
- for indoor use only in areas not exposed to direct UV radiation
- Max. ambient temperature inside and outside the control cabinet in accordance with the technical data (see "**Fehler! Verweisquelle konnte nicht gefunden werden.**")

Qualified project planning and design, proper transport, storage, installation, use and careful maintenance are essential to the flawless and safe operation of the automation system. The automation system may only be used within the scope of the data and applications specified in this documentation and associated user manuals.

The automation system must only be used:

- as intended
 - in a technically perfect condition
 - without any unauthorised modifications
 - by qualified users
- ▶ Observe the rules of the employer's liability insurance association, the technical inspectorate, and the VDE (Association of German Electrical Engineers) or corresponding country regulations.

The device is intended for installation into a suitable cut-out on industrial machines and systems in indoor areas.

- ▶ When installing the device, check that the seal profiles are undamaged.
- ▶ For operation, refer to the applicable statement of ambient conditions (see "**Fehler! Verweisquelle konnte nicht gefunden werden.**").

1.7. Transport and storage

The device is susceptible to impacts, heavy vibration, moisture and extreme temperatures.

Transport and storage

- ▶ Protect the device against major mechanical stresses during transport.
- ▶ Always pack the device in its original packaging for transport.
- ▶ For storage, refer to the applicable statement of ambient conditions (see "**Fehler! Verweisquelle konnte nicht gefunden werden.**").
- ▶ Protect the device against condensation and damp.

Devices with batteries/rechargeable batteries

Lithium metal batteries are hazardous items. The manufacturer's information specifies that they are subject to UN 3091 (must be permanently installed within the device).

The ADR 188 special regulations can be applied for transport.

Operation

- ▶ If the device has been stored or transported in cold weather or under conditions or large fluctuations in temperature, do not start to operate it until it has acclimatised to room temperature for the place it is used.
- ▶ If condensation is present, wait at least 12 hours before starting to operate the device.

1.8. Unpacking

On receipt of the device, a check must be made that it is complete and undamaged.

- ▶ Check the packaging for external damage.
- ▶ If the packaging is seriously damaged or if damage to the contents is evident: Do not proceed further with opening the packaging, instead immediately inform the transport company and your supplier.
- ▶ Remove the packaging and keep it safe for subsequent transport.
- ▶ Check the contents for evidence of damage in transport.
- ▶ Check the contents for completeness against the order documentation and keep all the delivery documentation for future reference. The delivery documentation contains important information about the device and is part of the product.
- ▶ If you discover damage in transport, or if the equipment delivered does not match the order: Inform the supplier immediately.

2. Safety

2.1. Safety related systems

The use of PLCs in safety-related systems requires specific measures. Wherever a PLC is to be used in a safety-related system, the user must be given comprehensive advice by the PLC manufacturer in addition to information on any available standards or regulations regarding safety installations.

- ▶ Before starting any work on devices, switch off all power feeds, including to peripherals.
- ▶ Keep all ventilation holes unobstructed.

Failure in certain components in an electronic control system may result in uncontrolled and/or unpredictable operational behaviour.

- ▶ All types of failure must be considered at the system level and the associated preventative measures identified.
- ▶ If necessary, request information from your automation system provider.

2.2. Safety instructions

CAUTION

Possible minor injuries and/or burns to the skin surface.

Failure to observe the safety measures may result in minor injuries / burns to the skin surface!

The device may be operated only when it is in good working order. Exposed sharp edges pose an injury risk.

- ▶ If you discover damage to the front glass of the device, do not continue to operate the device. Immediately disconnect it from the power supply.

The housing of the device can heat up considerably, especially at elevated ambient temperatures, due to the passive cooling of the internal components. The surface temperature may exceed the burn threshold depending on the duration of contact.

- ▶ If possible, avoid touching the rear panel of the device during operation.
- ▶ If you plan to perform any work on the device, such as installing or removing it in the control cabinet or connecting or disconnecting a cable, switch off the device and allow it to cool down for a while.
- ▶ It is recommended to wear personal protective equipment such as gloves when handling the heated device.

Working on the device

Do not start work on the device until all necessary safety precautions have been taken. Take precautions to avoid unforeseeable functional events and movements of the system.

- ▶ Bring the system into a safe condition.
- ▶ Switch the system and the device off.
- ▶ Secure the system against being switched on again.
- ▶ Disconnect the device from the system.

The casing of the device must not be opened.

- ▶ If work on the internal parts of the device is necessary, contact the manufacturer (see "Addresses").

2.3. Cybersecurity

- ▶ Never place the control unit on the Internet without additional protection mechanisms, this product is not designed for this purpose
- ▶ Change the default passwords specified on delivery
- ▶ Always use an upstream external firewall to prevent access from the outside to the inside.
- ▶ Use the security mechanisms of VPN server portals (e.g. IXON) to which the controller can actively connect via VPN or comparable mechanisms
- ▶ Always use https instead of http
- ▶ Deactivate unnecessary services such as (FTP/SSH/Webserver)

Contact person for cybersecurity of Berghof products:

Berghof Automation Product Security Incident Response Team

psirt.automation@berghof.com

3. Product description

The Ethernet Terminals B-Primis ET-Prime are high quality input devices with a display for connection to a control system for machines or systems. These terminals show the CODESYS Web visualisation or CODESYS Target visualisation, irrespective of whether the source of the visualisation is a Berghof PLC control unit or some other CODESYS control unit.

The connection level of the devices for all external connections is located on the back. These devices are intended to be installed in a prepared mounting cut-out in a flat surface.

All connections are of the plug-in type.

3.1. Overview ET-Prime 7/10/15

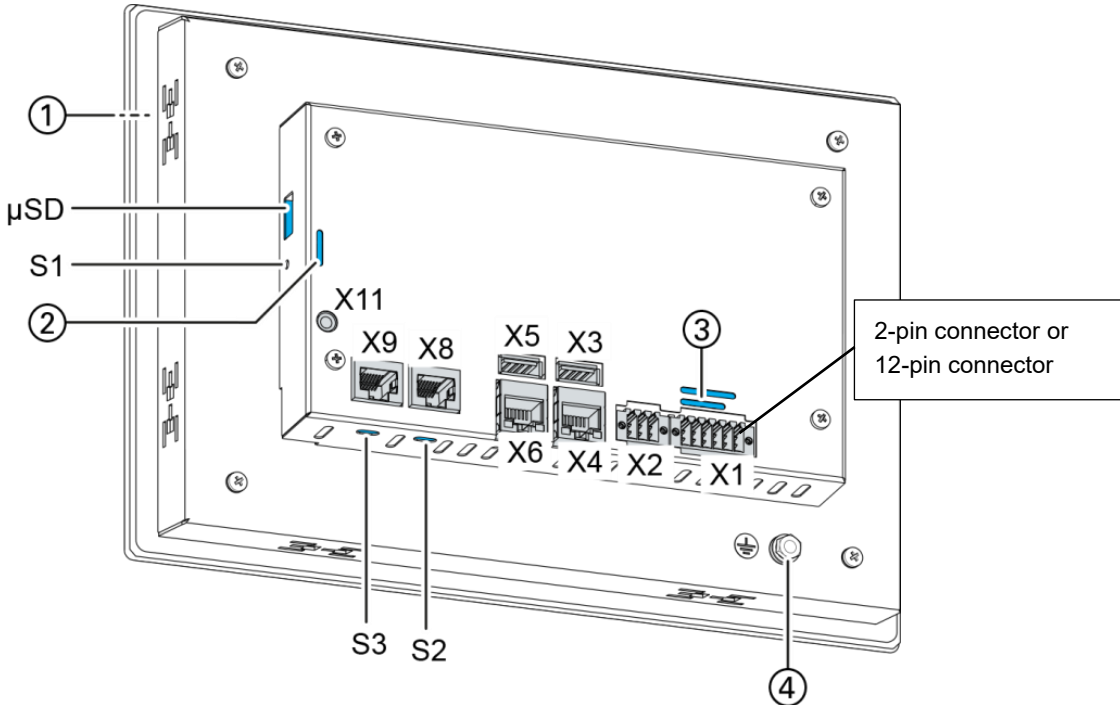

Fig. 1: Overview B-Primis ET-Prime 7/10/15 (rear view)

Item	Designation	Item	Designation
1	Display 7/10.1/15 inches	X6	unused
2	LEDs: Power, Run/Stop, Error	X8	unused
3	LEDs: Power	X9	unused
4	Earth connection	X11	Debug interface (do not use this - only for use by Berghof Service Engineers)
X1	Power supply 12-pin plug (2-pin plug for ET-Prime 10 and 15)	S1	Function button (do not use this - only for use by Berghof Service Engineers)
X2	unused	S2	unused
X3	USB 2.0	S3	unused
X4	Ethernet (ETH0)	μSD	unused
X5	USB 2.0 (only ET-Prime 7)		

3.2. Scope of delivery and accessories

Scope of delivery

- B-Primis DC-Prime Device
- Securing clip (6/8/14, depending on the device)

Accessories

The following accessories can be ordered using the device options (For more information see chapter 10.3)

- E-I/O connector, 12-pin (2x6), black Order n°. S-02020201-0601
- Connector, 2-pin black Order n°. S-02020201-0100
- Securing clips, Order n°. S-02060201-0100

3.3. Product features

Installation

The device is designed for installation in a front panel or in a control panel in a rough industrial environment.

Processor

In its the basic configuration the device is equipped with an 800 MHz ARM® CPU with a Cortex™-A9 core.

Ethernet interface

1 Ethernet interface with 10/100 Mbit/s

The Ethernet interface is used for standard Ethernet connections. TCP/IP and UDP/IP protocols permit flexible connections to visualisation software, higher-level control units and to the IT infrastructure.

USB interface

The USB host interface allows a wide range of peripherals to be connected to the device. This allows a USB stick to be used for updating the application or for downloading data directly.



USB sticks with FAT/FAT32 formatting are supported.

If you require support for other USB formats, please contact our Technical Support.

Summary of features

- ARM® CPU with Cortex™-A9 single-core (800 MHz)
- 1 USB host interface (USB 2.0)
- 512 MB RAM / 512 MB Flash
- 1 Ethernet 10/100 Base T interface

4. Installation

4.1. Preparation for front installation ET-Prime 7

The device is intended for installation from the front into a rectangular cut-out on a panel. The support material must be rigid and be from 1 to 3 mm thick.

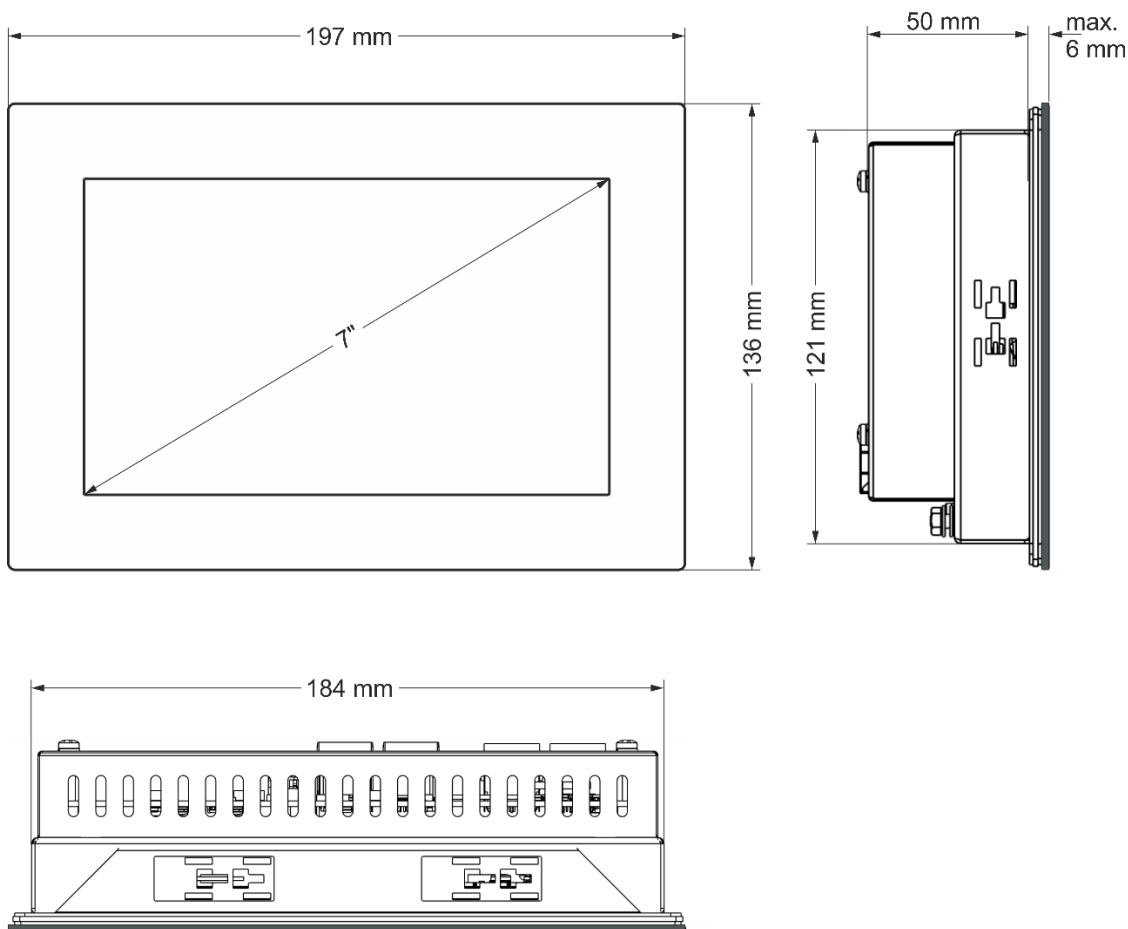

Fig. 2: Dimension ET-Prime 7

Requirements:

- To allow sufficient air circulation, it must be ensured that the device has a clear space of at least 20 mm all round at the rear.
- The max. ambient temperature inside the control cabinet must not exceed 55 °C in operation.
- The support material for the installation cut-out must be flat, sufficiently stable, and be from 1 to 3 mm thick.

NOTE

Damage to the device!

Installation on uneven support material can lead to mechanical stresses and cracks in the front face or malfunctioning of the touch screen.

- ▶ Make sure that the mounting points of the device are all in a common plane, with no more than maximum ± 0.5 mm variation.

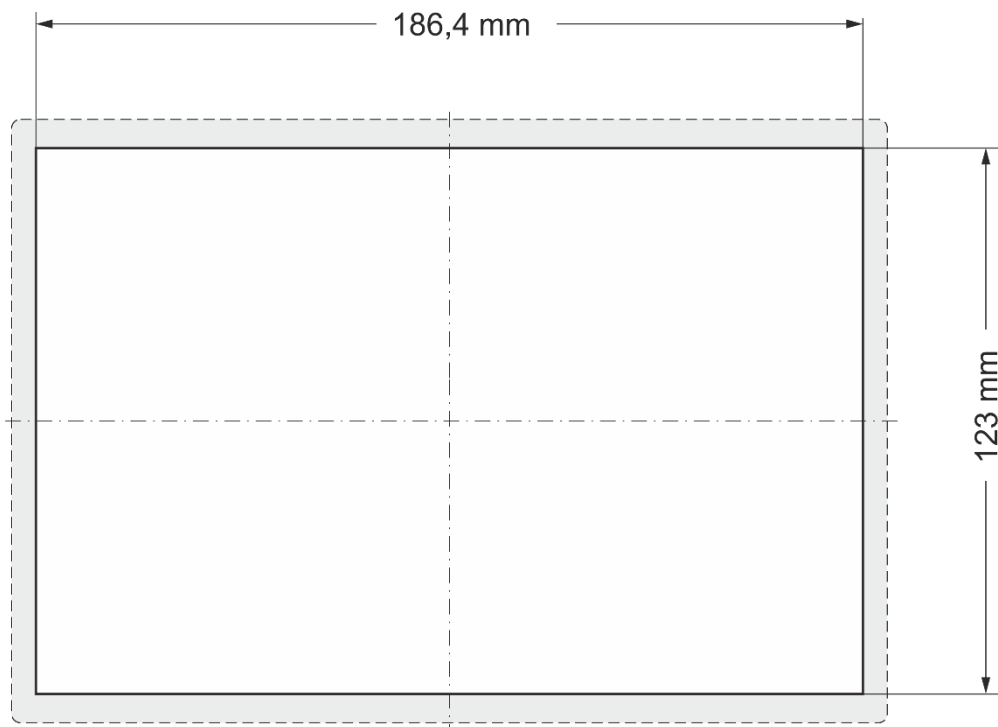

Fig. 3: Installation cut-out ET-Prime 7

- ▶ Cut a rectangular installation cut-out in the support material:

Height: 123 mm

Width: 186.4 mm

Max. corner radius: 1.5 mm



Optimum thickness of the support material: 1.0 mm to 3.0 mm

4.2. Preparation for front installation ET-Prime 10

The device is intended for installation from the front into a rectangular cut-out on a panel. The support material must be rigid and be from 1 to 3 mm thick.

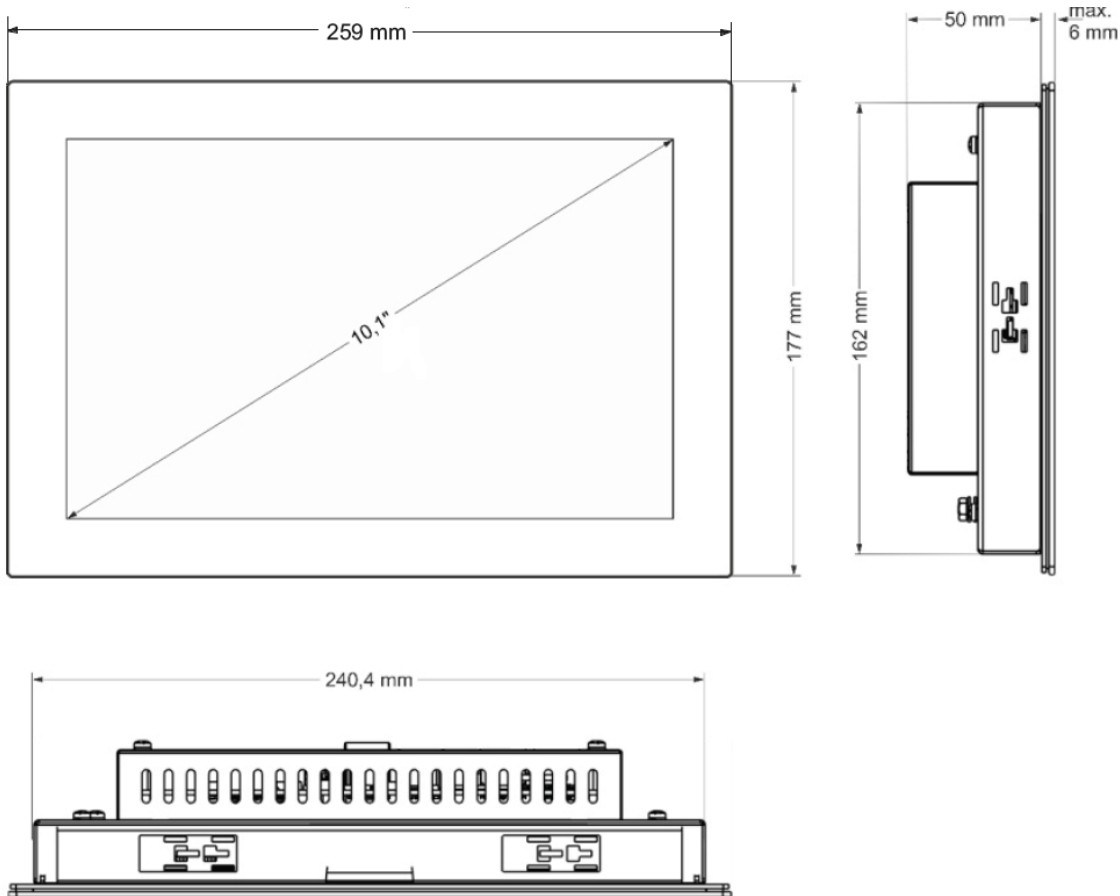

Fig. 4: Dimension ET-Prime 10

Requirements:

- To allow sufficient air circulation, it must be ensured that the device has a clear space of at least 20 mm all round at the rear.
- The max. ambient temperature inside the control cabinet must not exceed 55 °C in operation.
- The support material for the installation cut-out must be flat, sufficiently stable, and be from 1 to 3 mm thick.

NOTE

Damage to the device!

Installation on uneven support material can lead to mechanical stresses and cracks in the front face or malfunctioning of the touch screen.

- ▶ Make sure that the mounting points of the device are all in a common plane, with no more than maximum ± 0.5 mm variation.



Fig. 5: Installation cut-out ET-Prime 10

- ▶ Cut a rectangular installation cut-out in the support material:
 Height: 163 mm
 Width: 242 mm
 Max. corner radius: 1.5 mm



Optimum thickness of the support material:
 1.0 to 3.0 mm

4.3. Preparation for front installation ET-Prime 15

The device is intended for installation from the front into a rectangular cut-out on a panel. The support material must be rigid and be from 1 to 3 mm thick.

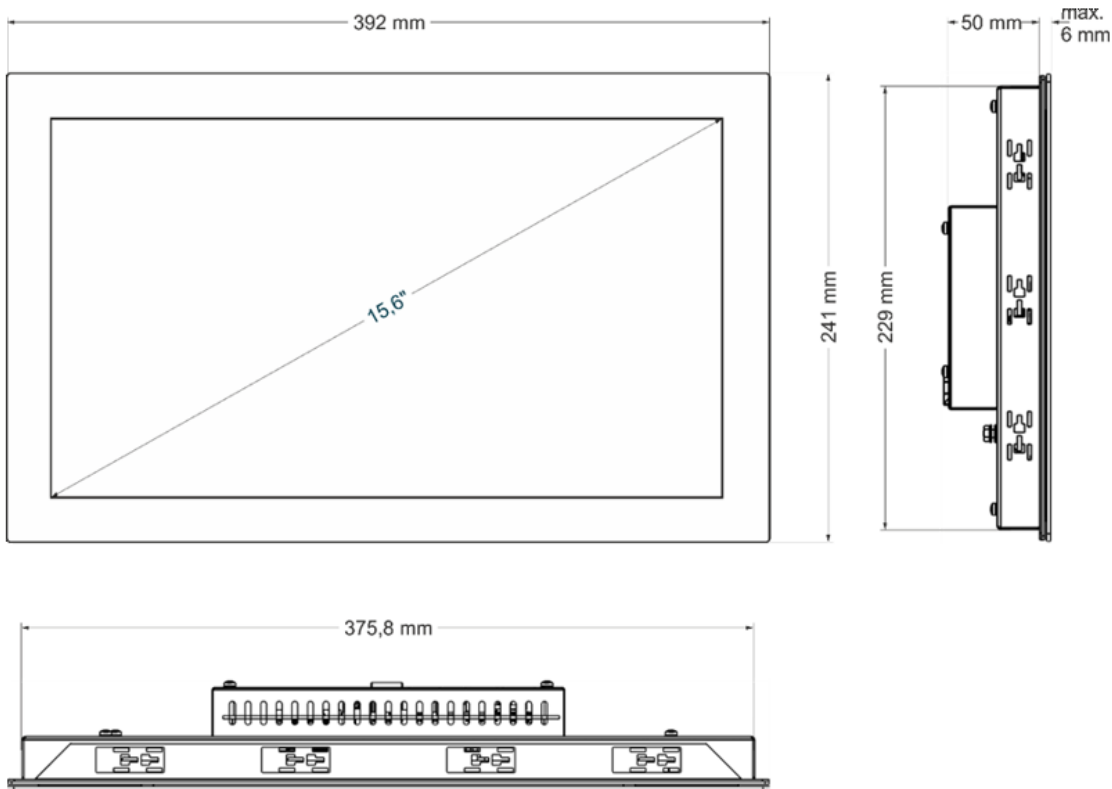

Fig. 6: Dimension ET-Prime 15

Requirements:

- To allow sufficient air circulation, it must be ensured that the device has a clear space of at least 20 mm all round at the rear.
- The max. ambient temperature inside the control cabinet must not exceed 55 °C in operation.
- The support material for the installation cut-out must be flat, sufficiently stable, and be from 1 to 3 mm thick.

NOTE

Damage to the device!

Installation on uneven support material can lead to mechanical stresses and cracks in the front face or malfunctioning of the touch screen.

- ▶ Make sure that the mounting points of the device are all in a common plane, with no more than maximum ± 0.5 mm variation.

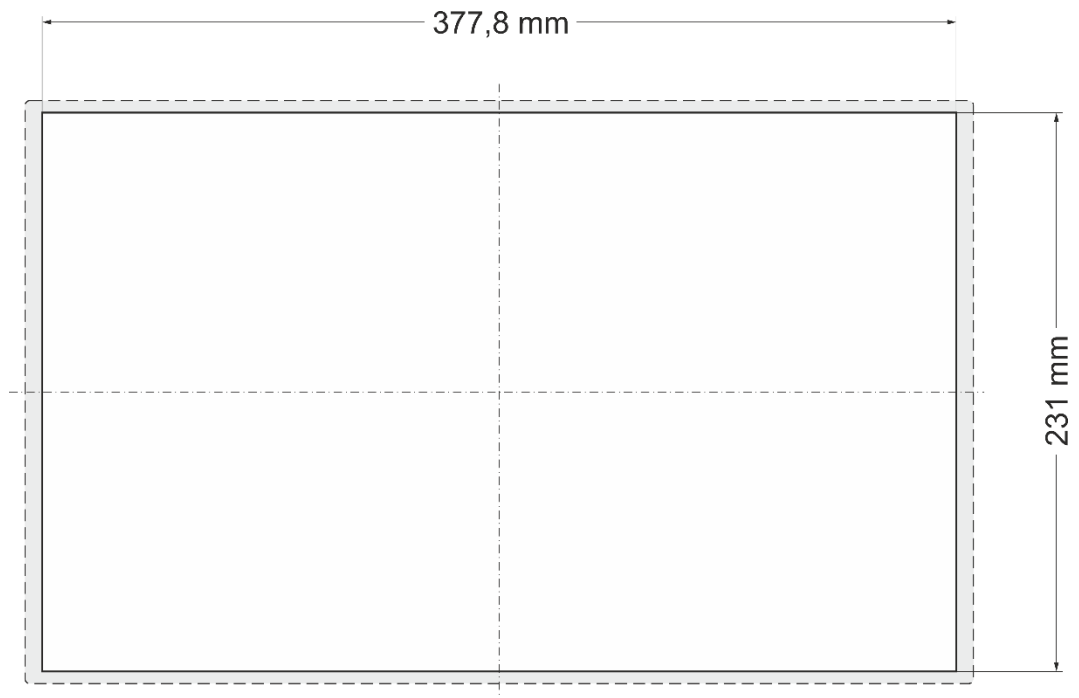

Fig. 7: Installation cut-out ET-Prime 15

- ▶ Cut a rectangular installation cut-out in the support material:
Height: 231 mm
Width: 377.8 mm
Max. corner radius: 1.5 mm

i Optimum thickness of the support material:
1.0 mm to 3.0 mm

4.4. Assembly

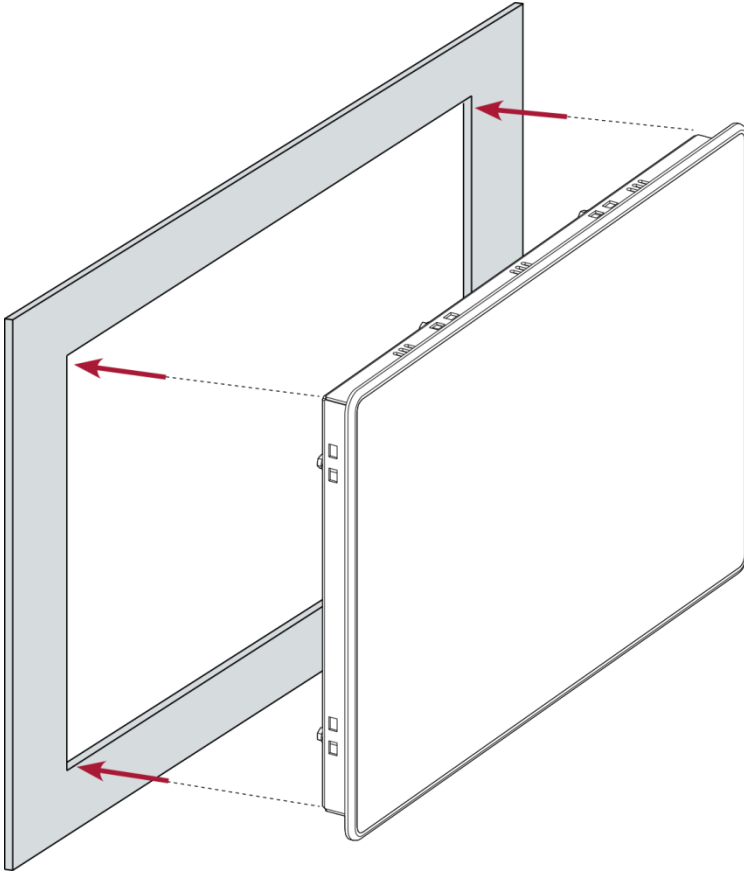

Fig. 8: Insertion into the installation cut-out

Requirements:

- The securing clips must not be attached to the device.
- 1. Making sure the alignment is correct, push the device evenly into the installation cut-out.

NOTE

Damage to the device!

If installation is performed carelessly the device can fall out of the installation cut-out or be damaged.

- ▶ Do not tilt the device.
- ▶ Restrain the device against falling until the securing clips have been tightened.

2. Make sure the device lies flush all round.

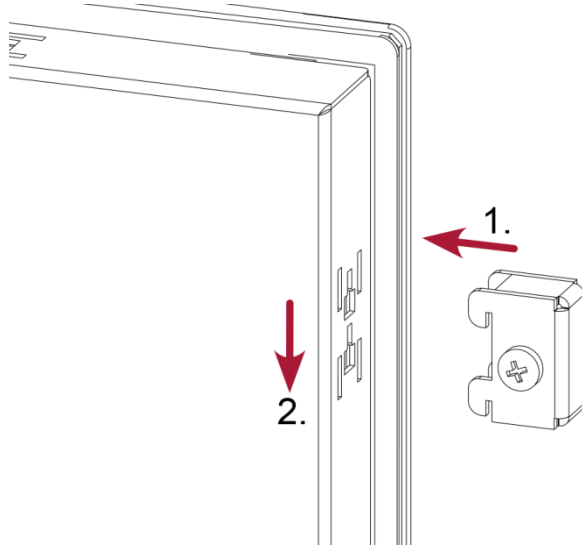

Fig. 9: Mounting the securing clips

3. Secure the device with 2 securing clips: Insert the securing clips into the cover at diagonally opposite points and tighten the screws finger-tight.

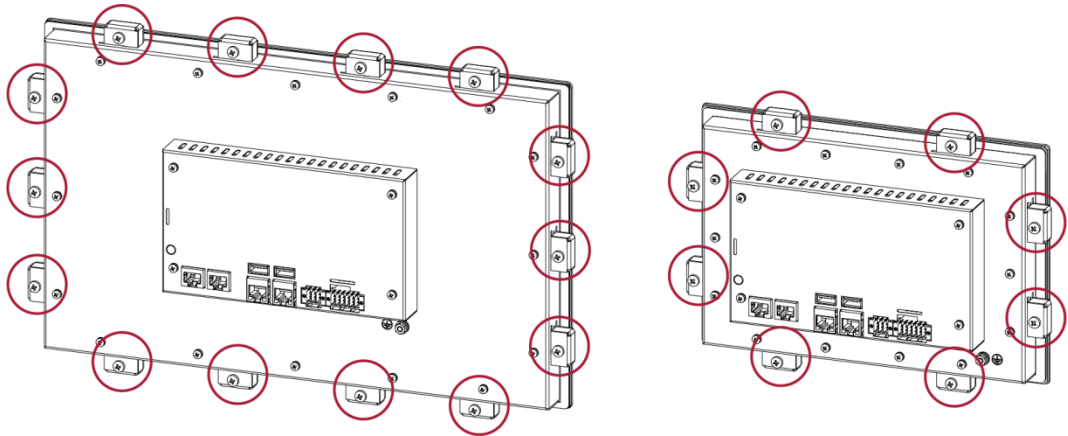

Fig. 10: Fully tightening the securing clips

4. Insert the other securing clips and tighten the screws in all the securing clips equally (max 35 Ncm).
 ET-Prime 15: 14 securing clips
 ET-Prime 10: 8 securing clips
 ET-Prime 10: 8 securing clips

5. Connection

⚠ WARNING

Uncontrolled and unpredictable operational behaviour!

Failure of certain components in electronic control systems may result in uncontrolled and unpredictable operational behaviour.

- ▶ All types of failure and the associated protection systems must be taken into account at system level.
- ▶ Comply with all automation system manufacturer instructions.

5.1. Power supply

The device is powered by an external 24 V DC power supply.

- ▶ Before plugging in the device, ensure that the external power supply meets the required specifications (type K to 61131-2).

External power supply (24 V DC)

Supply voltage	+24 V DC SELV (–15% / +20%)
Ripple current proportion	Max. 5 % The DC voltage level must not fall below 20.4 V.
Power consumption	B-Primis ET-Prime 7: Total max. 0,4 A at +24 V DC B-Primis ET-Prime 10: Total max. 0.6 A at +24 V DC B-Primis ET-Prime 15: Total max. 0.7 A at +24 V DC

Internal power supply

A power supply for the system electronics for an input voltage of 24 V DC (–15% / +20%) is integrated into the device. The power supply has integrated protection against reverse polarity and surge current protection (1.2 A).

Installation

- ▶ All connections and cables must be laid so as to prevent inductive and capacitive interference causing any damage to the device.
- ▶ Ensure that the infeed lines provide adequate current and voltage carrying capacity.

5.1.1. Connecting the power supply

⚠ CAUTION

Live parts!

- ▶ Before starting any work on the device, switch off all power feeds, including peripherals.

B-Primis ET Prime 10/15

- ▶ Connect the power supply to plug X1 according to the following table.

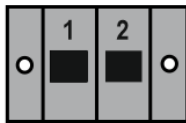

Fig. 11: Spannungsversorgung Stecker X1 ET-Prime 10/15

Power supply plug X1 ET-Prime 10/15		
Pin	Designation	Assignment
1	L0+ 24 V	Power supply 24 V DC (–15 %/+20 %) B-Primis ET-Prime 10: max. 0,6 A B-Primis ET-Prime 15. Max. 0,9 A
2	GND	GND

The following counterparts have been tested for the SC-SMT 3.5 connector (Weidmüller) and may be used with the device:

- BLZF 3.50/02/180

B-Primis ET Prime 7

- ▶ Connect the power supply to plug X1 according to the following table.

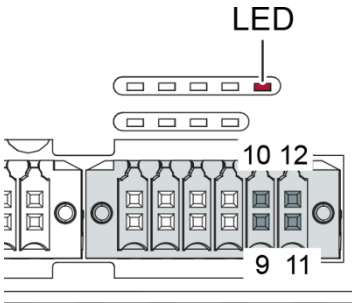

Fig. 12: Power supply ET-Prime plug X1 ET-Prime 7

Power supply plug X1 ET-Prime 7		
Pin	Designation	Assignment
9	L0+ 24 V	Power supply 24 V DC (-15 %/+20 %) B-Primis ET-Prime 7: max. 0,4 A
10		unused
11	GND	M0 / GND
12	L0+ 24 V	Power supply 24 V DC (-15 %/+20 %) B-Primis ET-Prime 7: max. 0,4 A

The following counterparts have been tested for the S2C-SMT 3.5 (Weidmüller) plug-in connector and are approved for use with the device:

- B2CF 3.50/12/180

5.2. Data connections

5.2.1. Block circuit diagram

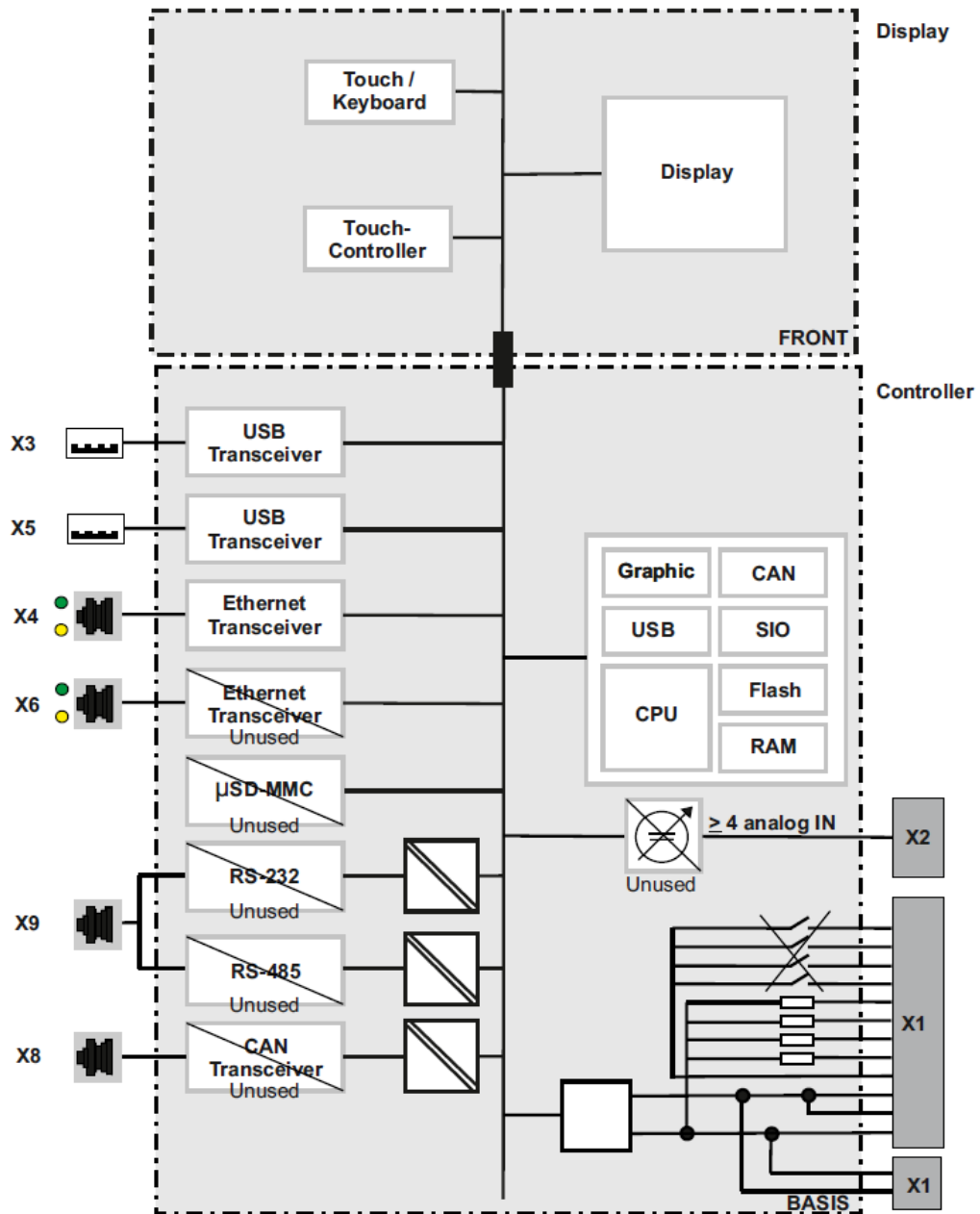

Fig. 13: Block circuit diagram ET-Prime 7/10/15

5.2.2. Ethernet interface (X4)

The on-board Ethernet adapter has one 10/100-Base-T RJ-45 port for connection to the network. The Ethernet interface X4 can be used as a standard Ethernet interface.

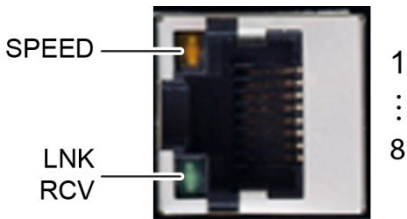

Fig. 14: Ethernet interface X4

Assignment of Ethernet interface plug X4			
Pin	Assignment	Pin	Assignment
1	TX+	5	NC
2	TX-	6	RX-
3	RX+	7	NC
4	NC	8	NC

LEDs		
LED	Colour	Meaning to IEEE 802.3 clause 25
LNK/RCV	green	Link, Data Receive Flashing: connection active; data transfer in progress Off: no connection established
SPEED	yellow	On = 100 Mbit/s Off = 10 Mbit/s

5.2.3. USB interface

Devices with a USB interface can be connected to the USB host port (Rev. 2.0). Suitable USB device classes are:

USB stick, keyboard or USB-Serial adapter



B1
:
B4

Fig. 15: USB interfaces X3 and X5

Assignment of USB interface connectors X3 and X5			
Pin	Assignment	Pin	Assignment
B1	VCC	B3	D+
B2	D-	B4	GND

NOTE

Damage to USB stick and malfunction due to data loss!

Removing a USB stick while it is still in use and data are being transferred can render the USB stick unusable. Open files which can no longer be accessed because the USB stick has been removed can block the device.

- Therefore ensure that all operations are complete before removing the USB stick.

NOTE

Damage to property and malfunctions due to data loss!

The USB interface is protected against overloading (> 0.5 A). In the event of a short circuit during operation, the control unit may trigger a reset of the system.

Substantial property damage and damage to the USB device may ensue.

- Before using a USB device, check carefully its power requirements.

NOTE

Failures and malfunctions will occur if direct connections are made to signal earth!

- Use only USB devices that have no direct connection between signal earth and the housing.



The USB interface plug is designed to withstand 1,000 plugging and unplugging cycles.

6. Operation

6.1. Switching on and off

NOTE

Damage or malfunction!

- ▶ Do not insert, connect, undo or touch any connections whilst the device is in operation.
 - ▶ Before starting any work on the device, switch off all power feeds, including those to any connected peripherals (sensors and programmable devices etc. with independent power supplies).
-

NOTE

Damage to property!

- ▶ Before connecting the power supply, ensure that all cabling and the polarity of all the connections are correct.
-

Switching on

The device does not have an on/off switch. The device starts automatically when the system is switched on or the power is connected.

Switching off

The device is switched off when the system is switched off or the power supply is disconnected.

6.2. Initial Setup of the device

6.2.1. Configuration

The device must be connected to the network with the correct settings before it can be used.

NOTE

Damage to property!

- ▶ Before connecting the power supply, ensure that all cabling and the polarity of all the connections are correct.

1. Supply the device with power (24 V).
After the start the current network settings are displayed (server IP, IP address and network mask).

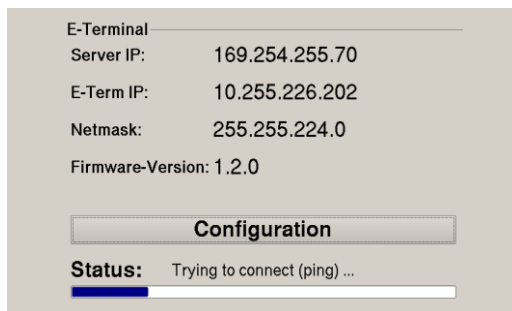

Fig. 16: Start page, with network settings

2. Press the "Configuration" button.
A page with further information appears.

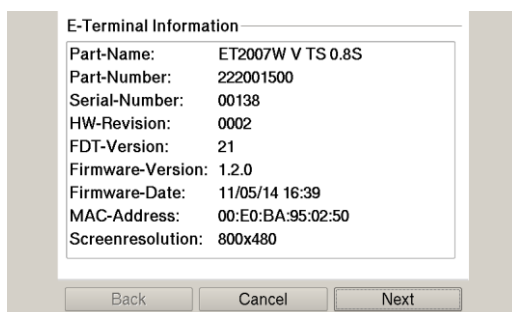

Fig. 17: Information page

3. Press the "Next" button.
The page with the network settings of the device appears.



Fig. 18: Network settings of the device

4. If necessary, press the "Edit" button and change the network settings as required (IP address, network mask, gateway).
5. Press the "Next" button.

The page with the settings for the server IP and Lifeguard appears.

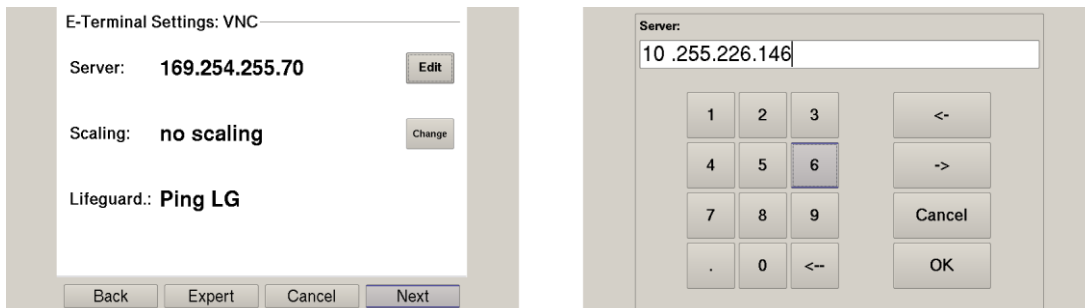

Fig. 19: Setting the server IP

6. If necessary, press the "Edit" button and change the server IP as required.
7. Press the "Expert" button to change the Lifeguard setting.
The page with the Expert settings will appear.
– OR –
Press the "Next" button and skip to the following page.

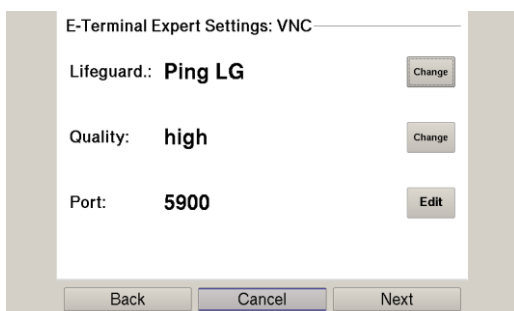

Fig. 20: Changing the Lifeguard setting

8. Depending on the controller version, press the "Change" button to change the Lifeguard setting:
 CODESYS V2: "BERGHOF VNC LG"
 CODESYS V3: "Ping LG"
9. Press the "Next" button to skip the following pages with until the page with the summary of the network settings appears.

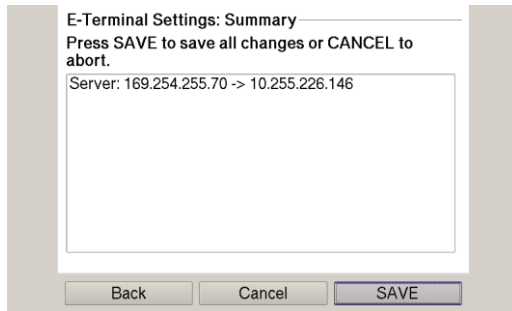

Fig. 21: Summary of the network settings

10. If no settings were changed, press the "OK" button.
 The main screen of the device will be displayed.
 – or –
 Press the "Save" button.
 The settings will be saved and the device will restart automatically.
11. Connect the device to the controller, using the network cable.

The device is now configured and ready for use.

6.2.2. Web Terminal

Before the device can be used in web-terminal mode it must be connected to the network with the correct settings before it can be used. Please read chapter 6.2.3 Configuration (B-Primis ET-Prime) for details.

1. Supply the device with power (24 V).
2. After the start the current network settings are displayed (server IP, IP address and network mask).
3. Press the "Configuration" button and then press the "Next" button.
4. The page with the network settings of the device appears.
5. Press the "Expert" button and then press the "Change" button to switch the device into a web terminal.



Fig. 22: Switching into web terminal mode

6. Press the "Next" button to skip the following pages until the page with the summary of the existing settings appears.
7. Press the "Save" button. The settings will be saved and the device will restart automatically.

After the start-up, the device is in web terminal mode.



The "Configuration" button is accessible for only a brief time after the start-up. After a few seconds, the device starts its integral browser and blocks the "Configuration" button.

Once this has happened, the only way to access the "Configuration" button is to restart the device again.

8. Directly after the start-up, press the "Configuration" button.
9. Press the "Next" button to skip the IP settings until the page with the Visu URL appears.
10. Press the "Edit" button.
11. Input the desired URL and confirm by pressing the "OK" button.

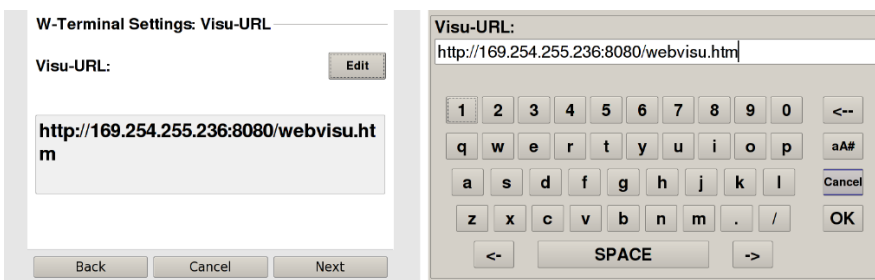

Fig. 23: Setting the Visu URL

12. Press the "Next" button to skip the following pages until the page with the summary of the existing settings appears.
13. Press the "Save" button.

The settings will be saved and the device will restart automatically.

After the restart, the device starts its integrated browser and automatically loads the configured URL setting of the visualization.

6.3. Status indicators

The status display function is dependent on the software development environment used in conjunction with the device.

The operating status LEDs show the current status of the power supply, the module mode and any error messages.

The LEDs of the ET-Pro series are controlled by the firmware.

Location of the status LEDs

The Run/Stop and Error LEDs display the system status.

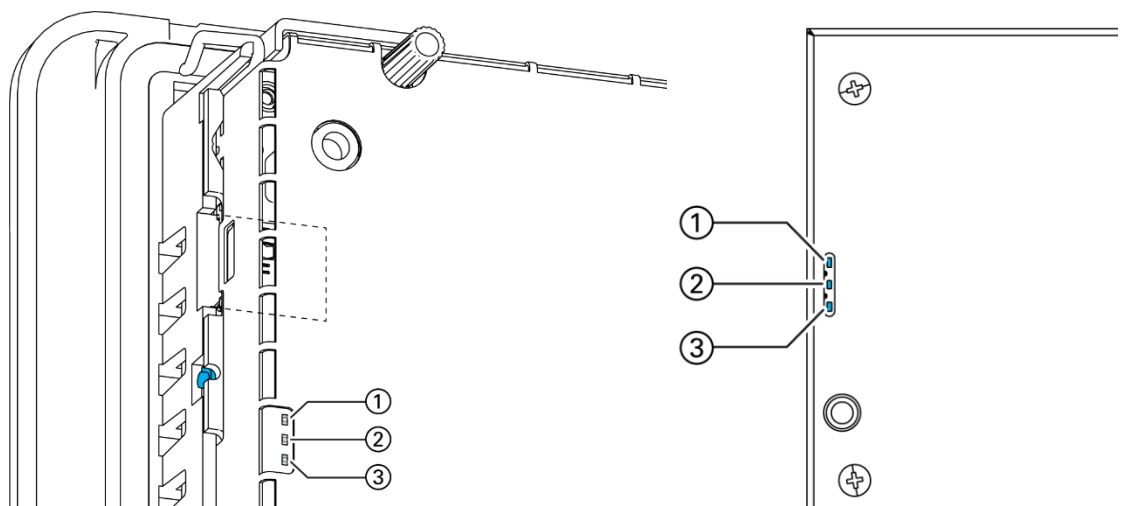

Fig. 24: Location of the status LEDs for the ET-Pro 4/7 (left) and 10/15 (right)

LED		description
1	Power (green)	Shows that the power supply to the electronics is correct.
2	Run/Stop (yellow/green/red)	Shows the system statuses.
3	Error (red)	Shows the device has stopped due to an error.

Meaning of the LEDs

System statuses are shown using flashing signals on the Run/Stop LED in yellow.

Continuous lighting of the Run/Stop LED in red or green indicates CODESYS operating states.

As long as the Run/Stop LED flashes yellow: the device is in use and must not be switched off.

The device does not show warnings via the LEDs during start-up.

6.4. microSD-Card

WARNING

Serious injury as a result of uncontrolled and unpredictable operational behaviour!

Inserting or removing the microSD card can result in the device malfunctioning. Failure in electronic control systems may result in uncontrolled and unpredictable operational behaviour.

- ▶ Insert or remove a microSD card only when the device is switched off.
-

The microSD interface is not supported in the ET-Prime series!

6.5. Troubleshooting

6.5.1. No network connection

- ▶ Check the cabling / switch.
- ▶ Check whether an IP address has been duplicated.
- ▶ Check the network settings on the PC: The subnet and the subnet mask settings must be the same as those for the controller.
- ▶ Check the firewall / anti-virus programs on the PC.
- ▶ Check the Lifeguard settings.

7. Maintenance and service

Repairs and corrective maintenance may be carried out only by the manufacturer or authorised customer service centres.

7.1. Maintenance

WARNING

Uncontrolled and unpredictable operational behaviour!

Failures or malfunctions may result in uncontrolled and unpredictable operational behaviour.

- ▶ Do not insert, connect, undo or touch any connections whilst the device is in operation.
- ▶ Before starting any work on the device, switch off all power feeds, including those to any connected peripherals (sensors and programmable devices etc. with independent power supplies).

If the device is used correctly it should not require maintenance.

- ▶ Make sure all the ventilation holes are kept free of obstructions.
- ▶ Do not open the device. Contact the customer service if work is required on the device.

7.2. Cleaning

NOTE

Damage to the front panel!

The front panel is of glass and must not be exposed to any mechanical or chemical stress.

- ▶ Do not use any high-pressure cleaners or steam jets.
 - ▶ Do not use any corrosive cleaning products, any thinners, any abrasive media or any hard objects.
 - ▶ Do not apply any undue force to the front face. Do not bend the device.
 - ▶ Do not place any heavy, hard or sharp-edged objects on the device.
 - ▶ Do not dismantle the devices.
-
- ▶ To avoid faults due to inadvertent activation, switch the device off before cleaning the front panel.
 - ▶ Clean the surfaces using only a dry, lint-free cloth.
 - ▶ Clean the glass only with normal window-cleaning agents or alcohol solutions.

8. Uninstallation

1. Disconnect the device and its peripherals from the power supply.
2. Unplug all plug connectors and cables.

NOTE

Damage to the device!

If uninstallation is performed carelessly the device can fall out of the installation cut-out or be damaged.

- ▶ Do not tilt the device.
- ▶ Secure the device against falling, especially when taking it out of the installation cut-out.

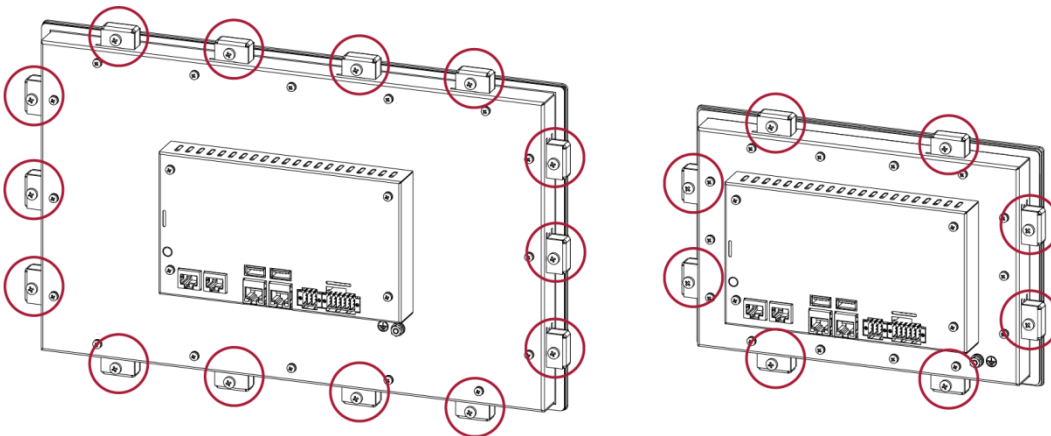

Fig. 25: Undoing the screws

3. Undo the screws on all the securing clips equally.
 - ET Prime 15 : 14 securing clips
 - ET Prime 10: 8 securing clips
 - ET Prime 7: 6 securing clips

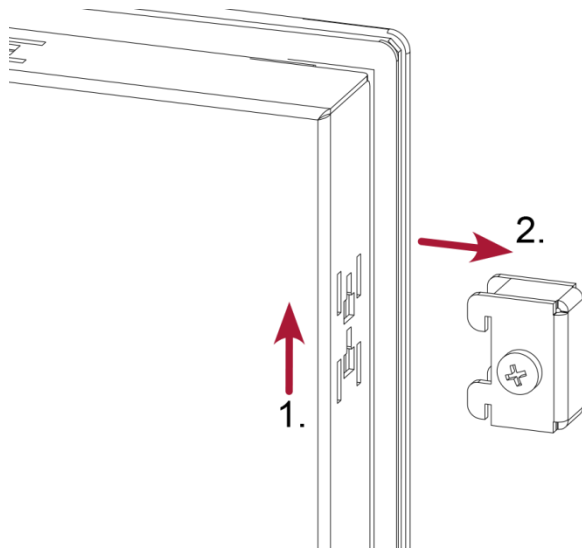

Fig. 26: Removing the securing clips

4. Removing the securing clips.

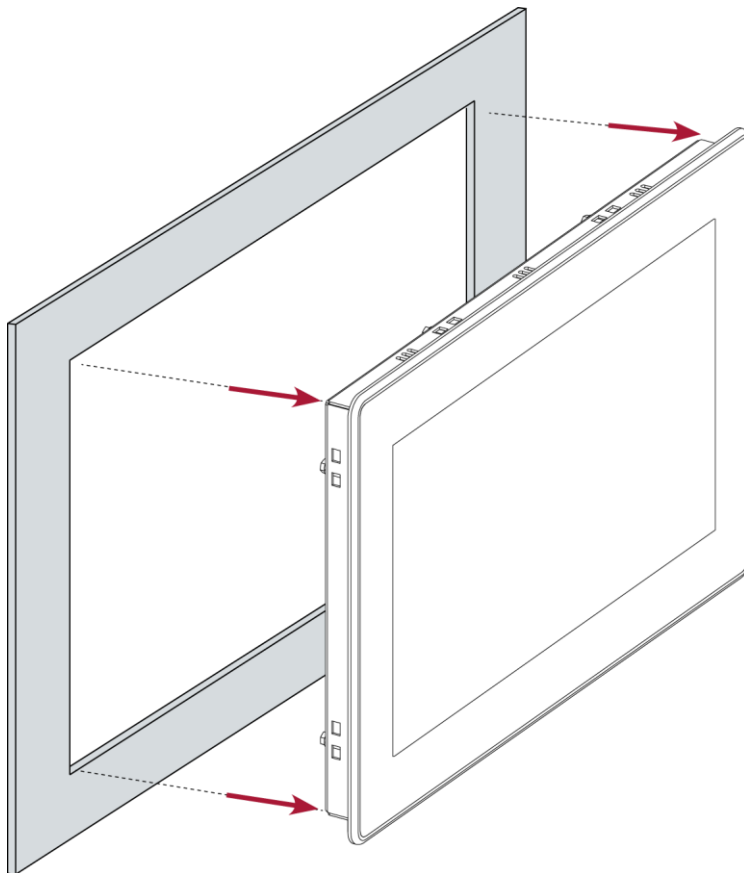

Fig. 27: Pushing the device out of the installation cut-out

5. Push the device evenly forwards out of the installation cut-out.

9. Disposal

The device contains the following components which need to be disposed of separately:

- Metals
- Electronic components
- Battery

The respective national regulations for disposal of electrical devices in B2B trade are applicable.

The following options are available for disposal of the device:

Disposal by the manufacturer

Unless agreed otherwise, devices can be sent back for disposal.

Disposal in accordance with regional regulations

- ▶ Dismantle the device and disassemble it completely into its component parts.
- ▶ Send the metal parts for metal recycling.
- ▶ Sort the electronic parts (circuit boards, drives etc.).
- ▶ Dispose of the electronic scrap in accordance with the national laws and regulations.
- ▶ Check that the battery is fully discharged.
- ▶ Dispose of the battery in accordance with the national laws and regulations, via an authorised collection point.

10. Information and options

Ethernet Terminal	B-Primis ET-Prime 15	B-Primis ET-Prime 10	B-Primis ET-Prime 7
Display			
Display	Full HD	WXGA	WVGA
Across diagonals	15.6"	10.1"	7"
Order no.	S-01010203-0108 S-01010203-0208	S-01010203-0105 S-01010203-0205	S-01010203-0104 S-01010203-0204
Resolution	1920 x 1080 Pixel	1280 x 800 Pixel	800 x 480 Pixel
Colours	TFT: 16.7 M (24 Bit/Pixel)		
CPU, user memory			
CPU	800 MHz ARM® CPU mit Cortex™-A9 Single Core		
Program memory (flash)	2 GB		
data memory (RAM)	512 MB		
Dimensions and weight			
Dimensions (WxHxD)	392 x 241 x 56 mm	259 x 177 x 56 mm	197 x 136 x 56 mm
Weight	approx. 3 kg	approx. 2.5 kg	approx. 2 kg
Operating conditions			
Operating temperature	0 °C to 55 °C (front and rear of the device; in compliance with installation requirements)		
Relative humidity	max. 85%, non-condensing		
Transport and storage			
Operating temperature	-20 °C to +70 °C		
Relative humidity	max. 85%, non-condensing		
Operation			
Installation	Removable securing clips		
Certification	CE (EN 61131-2)		
Touch operation	Capacitive, single-touch		

Ethernet Terminal	B-Primis ET-Prime 15	B-Primis ET-Prime 10	B-Primis ET-Prime 7
Shock resistance			
Vibration	sinusoidal (EN 60068-2-6) test: Fc 10...150 Hz, 10 m/s ²		
Shock	15 G (approx. 150 m/s ²), 11 ms duration, sinusoidal half-wave (EN 60068-2-27) Test: Ea		
EMC, protection rating			
Emitted interference	EN 61000-6-4, industrial area		
Immunity to interference	EN 61000-6-2, industrial area		
Protection class	III		
Insulation strength	EN 61131-2; 500 VDC test voltage		
Protection type	IP20, Front IP55		
Power supply (24 V power supply unit)			
Supply voltage	+24 VDC (-15 % / +20 %) SELV max. ripple component 5%		
Power consumption	max.0,9 A at +24 V DC	max.0,6 A at +24 V DC	max.0,4 A at +24 V DC
Protection against reverse polarity	Yes		
Ethernet interface			
No. / type of interface	1x 10/100 Base T		
Connection system	RJ45		
Protocols	TCP/IP		
USB interface			
No. / type of interface	2x host USB 2.0 / USB plug type A		
No. plugging/unplugging cycles	max. 1,000		
Additional functions			
microSD card slot	no function		

10.1. Nameplate

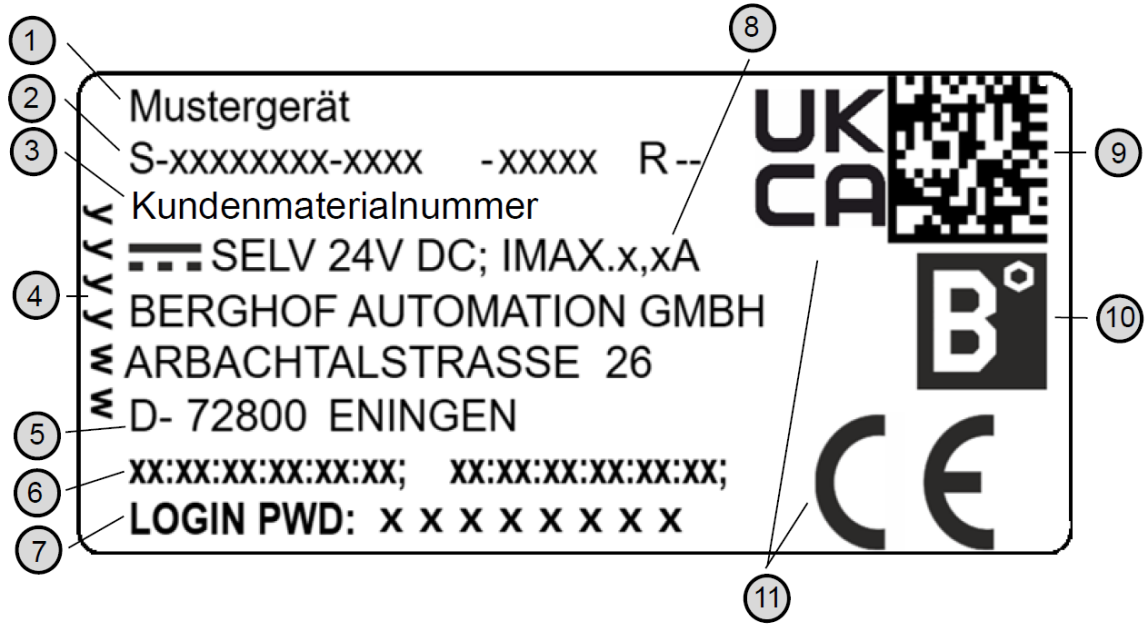

Fig. 28: Nameplate

Item	Designation	Item	Designation
1	Product description	7	Default password
2	Order no./serial no. / version identification	8	Supply voltage and maximum current
3	Customer material number	9	QR code (identification no.)
4	Production date (year/week)	10	Manufacturer's logo
5	Manufacturer (manufacturer's address)	11	Conformity marking
6	MAC address of the unit		

10.2. Device variations and identification

Bezeichnung	Bestellnummer	Merkmale
ET-Prime 7 S01	S-01010203-0104	7" Display, TargetVisu (VNC Client)
ET-Prime 7 S02	S-01010203-0204	7" Display, TargetVisu (VNC Client), Web-Visu (Webclient, html 5)
ET-Prime 10 S01	S-01010203-0105	10,1" Display, TargetVisu (VNC Client)
ET-Prime 10 S02	S-01010203-0205	10,1" Display, TargetVisu (VNC Client), WebVisu (Webclient, html 5)
ET-Prime 15 S01	S-01010203-0108	15,6" Display, TargetVisu (VNC Client)
ET-Prime 15 S02	S-01010203-0208	15,6" Display, TargetVisu (VNC Client), WebVisu (Webclient, html 5)

10.3. Options and Extensions

The options are ordered via the composition "Order number Option1 Option2 ...".

In addition to the order number, additional expansions in the form of hardware and software options are identified as follows:

option code	option type
S000-S999	Software Option e.g.: Fieldbusses
H000-H999	Hardware Option e.g. Connectors, Certificate
C000-C999	Custom Specific Option e.g. customized front

The following options are possible for the ET-Prime:

Option	Comment	Type of Option
H001	Stecker-Set (Weidmüller BLZF 3.50/02/180)	Hardware
H100	UL zertifiziert	

For more detailed and up-to-date information on the options available for this device, please refer to the product catalogue or the homepage.

The additional features included or installed in the respective device are listed on the option label. This label can be found on the device and/or on the packaging.



Fig. 29: Optionslabel

11. Standards and certificates

11.1. Standards

Applicable directives

- EMC directive 2014/30/EU
- RoHS directive 2011/65/EU

Applicable standards

- Standard
EN 63000:2019-05
- PLC standard
EN 61131-2:2008-4
- Emission standard
EN 61000-6-3:2012-11
- Safety provisions
DIN EN 61010-2-201
- Technical documentation for the assessment of electrical and electronic equipment with regard to the restriction of hazardous substances
EN 50581:2012

11.2. Declaration of conformity/Technical data

The declarations of conformity, technical data and further information can be found on our website at:

<https://www.berghof-automation.com/downloads>

Select the appropriate area (automation technology) and complete the form. Information on data protection can also be found on the page.

The technical data for ET Prime / 7 / 10 / 15 can be found in the display controls category.

If a document is missing, it can be requested via our contact form at

<https://www.berghof-automation.com/kontakt>

12. Customer services / addresses

Repairs and corrective maintenance may be carried out only by the manufacturer or authorised customer service centres.

12.1. Customer service

Berghof Automation GmbH
Arbachtalstrasse 26
72800 Eningen
Germany
T +49.7121.894-183
F +49.7121.894-100
e-mail: support-controls@berghof.com
<https://www.berghof-automation.com>

12.2. Repair service

Please send the goods to the Berghof repair service for repairs, stating the RMA number and a detailed description of the fault..

Berghof Automation GmbH
BU Automatisierungstechnik
Reparaturservice
Arbachtalstrasse 26
72800 Eningen

You can request the RMA number at:
www.berghof-reparaturservice.com

12.3. Addresses

CAN in Automation; international manufacturer and user organisation for CAN users in automation:

CAN in Automation e.V. (CiA)
Am Weichselgarten 26
91058 Erlangen
headquarters@can-cia.de
www.can-cia.de

EtherCAT Technology Group
ETG Headquarters
Ostendstraße 196
90482 Nuremberg
info@ethercat.org
www.ethercat.org

Beuth Verlag GmbH, 10772 Berlin
VDE-Verlag GmbH, 10625 Berlin
URL: www.iec.ch

13. Appendix

13.1. Information on copyright and software licence

The firmware of the devices contains der free software. Parts of this software are available under the following OpenSource licences, amongst others:

- GNU General Public License (GPL)
- GNU Lesser General Public License (LGPL)
- Mozilla Public License (MPL)
- FreeType License (FTL)

The source code of the free software may be requested from Berghof Customer Service within three years of delivery of the device, at cost price.

13.2. List of figures

Fig. 1: Overview B-Primis ET-Prime 7/10/15 (rear view).....	15
Fig. 2: Dimension ET-Prime 7	17
Fig. 3: Installation cut-out ET-Prime 7	18
Fig. 4: Dimension ET-Prime 10	19
Fig. 5: Installation cut-out ET-Prime 10	20
Fig. 6: Dimension ET-Prime 15	21
Fig. 7: Installation cut-out ET-Prime 15	22
Fig. 8: Insertion into the installation cut-out.....	23
Fig. 9: Mounting the securing clips	24
Fig. 10: Fully tightening the securing clips	24
Fig. 11: Spannungsversorgung Stecker X1 ET-Prime 10/15	26
Fig. 12: Power supply ET-Prime plug X1 ET-Prime 7	27
Fig. 13: Block circuit diagram ET-Prime 7/10/15.....	28
Fig. 14: Ethernet interface X4	29
Fig. 15: USB interfaces X3 and X5.....	30
Fig. 16: Start page, with network settings	32
Fig. 17: Information page.....	32
Fig. 18: Network settings of the device	33
Fig. 19: Setting the server IP	33
Fig. 20: Changing the Lifeguard setting	33
Fig. 21: Summary of the network settings	34
Fig. 22: Switching into web terminal mode	35
Fig. 23: Setting the Visu URL	35
Fig. 24: Location of the status LEDs for the ET-Pro 4/7 (left) and 10/15 (right).....	36
Fig. 25: Undoing the screws	39
Fig. 26: Removing the securing clips.....	40
Fig. 27: Pushing the device out of the installation cut-out.....	40
Fig. 28: Nameplate	44
Fig. 29: Optionslabel.....	46